



Legal metrology training

Metrology training in general - and legal metrology training in particular - present a number of characteristics which render their approach difficult. These characteristics are mainly:

- the wide variety of metrology applications: mechanics, electricity, electronics, acoustics, chemistry, atomic energy, biology, etc.;
- the rapidity of developments in scientific and technical fields, which require both training and training facilities to be constantly updated;
- the wide range of activities and responsibilities (research, maintenance of primary standards, calibration, type examination, verification, law enforcement, market surveillance, etc.), which necessitate various levels of education (scientists, engineers, inspectors, technicians, etc.); and
- the fact that in any given country, the number of persons requiring training at each level of education and for each application may only be very small, thus rendering permanent training facilities expensive and difficult to manage.

All these facts explain why OIML activities aimed at developing and harmonizing the content of legal metrology training have to date progressed so slowly, and have practically been limited to the publication of a basic curriculum for legal metrology personnel (OIML D 14, 1989) and of a directory of existing training systems with an associated bibliography (OIML P 2, 1987). These two publications are now at least partly out of date and their revision should start soon. A number of informative papers have also been published in the OIML Bulletin.

However, things are now changing and significant progress has been made in certain countries and regions, especially offering training possibilities to developing countries.

Just as examples, for a number of years the *Deutsche Akademie für Metrologie* has organized training seminars on

specific legal metrology matters, in English. In France, the *École Supérieure de Métrologie* reopened last year and will offer high level training in industrial and legal metrology, in French and in English. Similar situations now exist in other OIML Member States.

The difficulty resulting from the low number of trainees at the national level may be alleviated for example by using shared training facilities, a solution which could be advantageously adapted at regional level. In the same way, the training of inspectors or technicians from developing countries may be facilitated by the "train-the-trainer" approach, as developed by the Australian National Standards Commission, whereby legal metrology experts are specially trained in a developed country before passing on their knowledge in their own country.

The development of new communication techniques also contributes to facilitating legal metrology training: videos or CD Rom's on the evaluation or verification of measuring instruments may be elaborated in certain developed countries, translated into different languages and used in developing countries. The Internet will offer increased possibilities, for example the use of virtual instruments associated with interactive software.

All these initiatives that are developing at national and regional levels must nevertheless be coordinated in order to avoid excessive duplication of efforts and divergences in training approaches. For example, training on the evaluation and verification of measuring instruments should be in line with the provisions of the relevant OIML Recommendations. This is why the "accreditation" or "certification" (some use the word "validation") of legal metrology training is becoming an increasingly important discussion topic within the OIML.

This issue of the OIML Bulletin offers Australian views on this problem, which will very shortly have to be carefully dealt with within the OIML. ■

VERIFICATION

Vehicle for the verification of truck scales

WOLFHARD GÖGGE and DETLEF SCHEIDT, Verification Authority of Rhineland-Palatinate, Bad Kreuznach, Germany

Rhineland-Palatinate, one of the 16 States of the Federal Republic of Germany (surface area about 20 000 km² - population four million) has about 1 200 truck scales. This means that a large number of initial verifications and (at 3-yearly intervals) subsequent verifications have to be carried out. According to the corresponding European Union recommendations, the initial verification may be carried out by the manufacturer if a recognized quality management system is used, provided that the process is supervised by the Verification Authority.

Market surveillance, i.e. the question of how the truck scales will metrologically function over a long period of time, is carried out by the Verification Authority. One tool is subsequent verification every third year, using standard weights that have been tested by the Authority. However, the verification of truck scales requires the use of weights with large nominal values (between 100 kg and 1 000 kg) and in order to move such heavy weights, auxiliary equipment has to be installed on the truck.

In principle it is imaginable that platform weighing machines may be tested without weights using hydraulic load installations, though up to now nobody has developed such a system. Nowadays almost all balances are provided with electronic equipment that can be tested relatively easily in the Verification Authority laboratory. However, this cannot substitute a complete check with standard weights at the site of a truck scale. This means that for truck scales to be verified, weights will still have to be transported, moved and loaded on site in the future.

This article concerns a Rhineland-Palatinate Verification Authority vehicle that has been in service for some years (see article in the OIML Bulletin No. 114, March 1989) and which was completely modified about two years ago; meanwhile much experience has been gathered with this new verification vehicle. A normal truck can be used for the construction of a verification vehicle, but with the following special features incorporated:

- Small distance between axles, so that high loads can be moved even onto small weighbridges;
- High-powered engine, so that the vehicle can be driven on public roads without slowing down other traffic (despite its heavy weight);
- Remote-controlled hydraulic crane;
- Supports that can be raised by hydraulic jacks for safe operation of the crane;
- Additional hydraulic supports for lifting up the truck's front axle, so that the necessary weights can be loaded even on very short weighbridges;
- The ratio of the standard weights compared to the weight of the truck when empty should be about 1:1. In this case the application of the substitution method according to OIML Recommendation R 76 is simple; and
- Removable top cover for easy unloading of the weights.

For the verification vehicle in question (Fig. 1) all these aspects have been taken into account and therefore:



Fig. 1 Verification vehicle. On the tractor: 25 rolling weights (500 kg each); on the trailer: 15 t block weights, forklift and passenger car



Fig. 2 Additional hydraulic support for lifting up the front axle

- The distance between axles is 4.55 m. Additional hydraulic supports are mounted behind the front wheels to lift up the front axle (Fig. 2);
- Engine power is 368 kW (500 bhp); and
- Maximum crane load (depending on the working radius) is between 1.6 t and 0.5 t for 3.6 m up to 8 m (Fig. 3).



Fig. 3 Unloading two rolling weights using a remote-controlled crane

The crane is operated by remote control, and the truck is equipped with supports which can be hydraulically drawn out when the crane is operating; the handling platform is equipped with an awning.

The loading area of the truck serves for the transport of weights of 12.5 t in the form of 500 kg cylindrical weights. The empty weight of the truck is also 12.5 t, therefore the maximum weight is 25 t.



Fig. 4 Trailer: block weights beneath the passenger car and to the right and left of the forklift, which is standing on the loading area

In order to be able to perform the testing procedure as prescribed, the necessary rolling weights have to be manipulated on the bridge without the use of any mechanical device after they have been unloaded using the crane. However, it transpired that there are not enough auxiliary personnel able to move the heavy weights and that the latter involve a high accident risk when they start rolling unintentionally (in Germany two people were killed by rolling weights).

The former truck scales verification equipment was equipped with rolling weights only. To counter the aforementioned problems, the trailer has been modified to cater for the safe handling of rolling weights. However, the tractor itself is still equipped with rolling weights just in case this facility is required under special circumstances.

The trailer was custom-designed so that it can also be used for the verification of small weighbridges; for this purpose supports are mounted on the trailer directly behind the front axle so that the trailer fits on a weighbridge of 4.10 m in length. The trailer has a total weight of 30 t, of which 15 t are standard block weights of 200 kg, 500 kg and 1 000 kg (Fig. 4). Because of the supports on the tractor and trailer it is possible to verify weighbridges even with very short platforms, i.e. a total load of 55 t (Fig. 5) on a weighbridge of length 8.80 m and a load of 44 t on a weighbridge of length 5 m.

Using block weights reduces the risk of accidents, but on the other hand the disadvantage is that they cannot be moved manually so this is done by a forklift with a loading capacity of 3 t. The forklift is used for loading and unloading the trailer (Fig. 6) as well as for positioning and removing weights on particular spots of the weighbridge according to the verification officer's instructions (Fig. 7).

The forklift is stored along with the trailer and is operated by the driver of the verification vehicle - there-



Fig. 5 Rear view of the trailer



Fig. 7 Moving standard weights to special spots on the weighbridge

fore external auxiliary personnel for moving the weights are no longer necessary.

When work with the forklift is finished, it is put back on the trailer using two ramp rails which can be moved up and down hydraulically. Since the forklift cannot mount such a steep ramp by itself, it is pulled up by an electric winch (Fig. 8). The remote control for this winch is operated by the driver of the forklift.

On a rack above the block weights there is also space to store a small car (Fig. 4). This has the advantage that the verification vehicle, which due to its exceptionally high load of 55 t is only allowed to use public roads with special authorization, can directly drive from one operation to the next. For all other trips - for example to a verification office or back home - the driver uses this car. Consequently the verification vehicle itself is only used when absolutely necessary.



Fig. 8 Forklift pulled up by a winch



Fig. 6 Unloading a 1 t block weight

The car has to be small enough to fit on the trailer, and since most of the time it is only used by one person, this does not pose a problem. The car in question is a Fiat Cinquecento with 40 kW (55 bhp) which is able to mount the two ramp rails (Figs. 9 and 10).

If necessary, the driver may spend the night in the driver's cab, which is quite comfortable. He can be reached at any time using a mobile phone.

The cylindrical and block weights on these vehicles are all standard weights and are tested and adjusted every six months by the Verification Authority. As permissible tolerances, the mpe in accordance with OIML R 47 is applied.

The running costs for the verification vehicle are 1 180 DM per day. If this is considered too high, the weights may be picked up at the Verification Office by the truck scale owner, who must ensure that he is equipped with a forklift, a crane and, of course, a truck



Fig. 9 Car driving up



Fig. 10 Car in its final position on the trailer (beneath the car, winch for pulling up the forklift)

to transport the weights. He must also use his own personnel to move and place them, and must later return them to the Verification Office.

The Rhineland-Palatinate Authority verification vehicle is fully booked throughout the year, except when repairs and maintenance work have to be carried out. The percentage of annual utilization is actually greater than 100 % since weighbridges are not only verified on weekdays but also on some weekends (on 23 Saturdays and Sundays in 1998). Weekend operation can be necessary because some companies cannot put their weighing instruments out of operation for a long time for maintenance and verification (on average 1.5 days) during the week. Therefore, they prefer to pay an extra charge for the weekend service.

A verification vehicle costs about 680 000 DM to purchase; annual income is about 290 000 DM less operating costs but including maintenance costs. This means

that the vehicle costs are depreciated after approximately 8 years.

The verification vehicle (including the driver) is self-financing - financial support is only necessary from the government for the initial capital - therefore outright purchasing is highly recommended.

The verification vehicle is also occasionally used for testing truck scales during the 3-year period. This is a chance to study the metrological behavior of road vehicle weighers during this period until the next subsequent verification is due.

Private companies own similar vehicles for testing truck scales and it is up to the owner of the truck scale whether he uses a privately operated vehicle or if he prefers the Verification Office one, but the periodical reverification itself is always carried out by an inspector of the Verification Authority. ■



Wolfhard Gögge



Detlef Scheidt



NAWI

A strain-load methodology for fast verification of medium capacity nonautomatic weighing instruments

DOTT. ING. GIUSEPPE ARDIMENTO, Weights & Measures Officer, Camera di Commercio, Industria, Artigianato ed Agricoltura di Napoli, Italy

Introduction

The classification adopted by a Local Authority for non-automatic weighing instruments (NAWI's) that are within its jurisdiction often depends on the type and quantity of standard weights required to carry out their verification.

Typically at the Local Metrology Authority of Naples, the following classification criteria are used:

- **Small capacity NAWI:** Class III accuracy weighing instruments up to 20 kg capacity. For these instruments, one officer can perform the verification alone according to the relevant technical standard [1] by using a complete set of M_1 20 kg standard weights [2].
- **Medium capacity NAWI:** Class III accuracy weighing instruments up to 1 000 kg capacity. For these instruments, a verification officer should have a sufficient number of M_1 20 kg standard weights available in order to test the instruments to full capacity. In these instances extra labor might be required or, alternatively, a Local Metrology Authority technical assistant may have to accompany the officer to help lift and place the weights onto the load receptor. The main concern when verifying this type of NAWI is having to carry up to 25 M_1 20 kg standard weights to many locations (from 5 to 10 per day).
- **High capacity NAWI:** Class III accuracy weighing instruments from 1 t to 60 t capacity. Italian Regulations specify that these NAWI's have to be verified by an officer using high capacity standard weights that meet the relevant OIML Recommendation requirements, and which have to be made available by the NAWI owner or by the service agency responsible for the NAWI maintenance program. The traceability of standard weights to the national mass standard is, in these cases, to be clearly demonstrated to the officer performing the verification. The total number of standard weights to be used is specified by the relevant technical standard (see subclause 3.7.3 of [1]).

Since carrying 25 M_1 20 kg standard weights around can be somewhat problematic, this paper describes a strain-load methodology to perform fast routine verifications of medium capacity NAWI by using an error characteristic estimating model based on the concept of the "sensitivity error" [5].

This method is intended for performing routine verifications of NAWI's that have a good compliance history: if a NAWI subjected to the present fast verification method fails the test, it shall not be considered as rejected, but rather as needing to be further examined according to the full verification procedure set out in the relevant standard [1]. Since the global population of NAWI's consists of a majority of compliant devices and not that many non-compliant ones, the time needed to complete the whole routine verification program can be reduced, resulting in an advantage for the Local Metrology Authority responsible for the program management.

1 Error sources in a NAWI

In a medium capacity NAWI the load receptor dimensions are small, especially when the NAWI is equipped with load cells; this occurrence is notably true for single point load cell equipped NAWI's. Thus the influence of off-center loading can be considered as a marginal factor affecting the accuracy in a well calibrated NAWI.

The offset error [5] can be clearly detected and (in a certain weight value range) can be cancelled by activating the NAWI zero-setting mechanism.

The linearity and hysteresis error [5] are mainly due to the load cells: these items can only be investigated in a restricted way during a routine inspection. Linearity performance can be evaluated by means of the accuracy test according to the relevant standard [1]. The hysteresis contribution to the error characteristic can be evaluated by determining errors during the loading and unloading processes in the course of the NAWI accuracy

test: an acceptable performance criterion is that in both processes, the error characteristic must be within the in-service mpe values as laid down by the regulation or standard.

Since the relevant European Directive [6] stipulates that electronic NAWI's have to be submitted to pattern approval, it can be assumed that the NAWI's behave in such a way that offset, linearity and hysteresis error characteristics were more thoroughly investigated at the time of pattern approval, and found to be within the mpe. Moreover, if the initial verification result is "OK", this can be considered as confirming that circumstance. Thus in a routine inspection, it can be assumed that the sensitivity error [5] is the main source of error when a NAWI is in service due either to incorrect calibration procedures or to electronic shift phenomena occurring in the analog components that process the signal emanating from the load transducers.

2 The sensitivity error model

The reasons described in section 1 above show that the NAWI's accuracy performance may be described by assuming that the relationship between the applied load L and the NAWI indication is a linear one: a NAWI having no error regardless of the load applied on the receptor would have the dotted straight line representing the unity function as shown in Fig. 1.

A NAWI having an error due to a sensitivity value (dI/dL) other than 1 would have the continuous red line plotted in Fig. 1, which is described by the equation:

$$I = aL \tag{1}$$

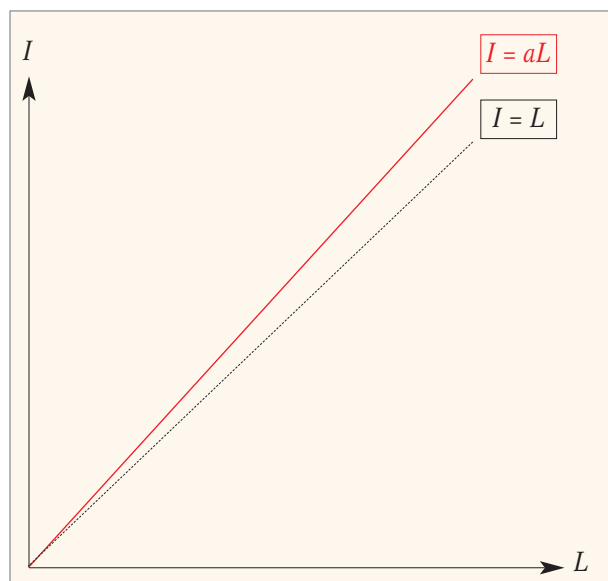

Fig. 1 Relationship between NAWI indication and applied load

where a is the slope (dI/dL). Thus the NAWI sensitivity error:

$$E = I - L \tag{2}$$

is proportional to the applied load, and in fact:

$$E = aL - L = (a - 1)L \tag{3}$$

Because of (3), the NAWI can be considered as having a behavior that is influenced by a predominant sensitivity error when the accuracy error rises proportionally as the applied load increases.

3 The strain-load fast verification approach

Once a NAWI has been installed and verified according to the relevant technical standard, it may be assumed that it is likely to retain the correct accuracy characteristics throughout its whole operating life. Thus subsequent verifications could be performed using an abridged procedure, only focusing on the main error sources such as the sensitivity error. This abridged verification can be deemed as being satisfactory provided that full verification tests and fast verification tests are performed alternately during the NAWI's operating life.

3.1 The strain-load method as a NAWI fast verification procedure

According to [4] a strain-load test is "the test of a scale beginning with the scale under load and applying known test weights to determine accuracy over a portion of the weighing range. The scale error for a strain-load test are the errors observed for the known test loads only. The tolerances to be applied are based on the known test load used for each error that is determined".

Since the relevant European technical standard does not allow for strain-load to be performed, but does allow for a substitution test to be performed (see subclause 3.7.3 of [1]) provided that the NAWI under test meets given repeatability requirements, the possibility has been investigated to combine the substitution test procedures with the strain-load method (which is faster) by means of an error characteristic estimating model. This model analyzes the error characteristic in the initial weighing range near to zero by using a limited number of test weights (up to 500 times the interval, e), extrapolates a linear characteristic from the initial weighing data and explores the error characteristic by means of a strain-load beginning with the NAWI loaded at 50 % (or more) of the maximum capacity.

Table 1 The initial loading process

Load	$I_i \uparrow$	$I'_i \downarrow$	Corrected I_i	Corrected I'_i
L_1	I_1	I'_1	$I_{1c} = I_1 - E_0$	$I'_{1c} = I'_1 - E_0$
L_2	I_2	I'_2	$I_{2c} = I_2 - E_0$	$I'_{2c} = I'_2 - E_0$
L_3	I_3	I'_3	$I_{3c} = I_3 - E_0$	$I'_{3c} = I'_3 - E_0$
L_4	I_4	I'_4	$I_{4c} = I_4 - E_0$	$I'_{4c} = I'_4 - E_0$
L_5	I_5		$I_{5c} = I_5 - E_0$	

(Note: E_0 is the near zero error determined according to subclause A.4.4.3 of [1]. In order to only consider the error due to the applied load and without including the zero error, the corrected indication $I_{ic} = I_i - E_0$ is calculated, E_0 being the near zero error as referred to above).

3.2 The estimating linear model

To determine the estimating linear model, the NAWI is loaded up to 500 e in progressive steps of 100 e each. The procedure is shown in Table 1, where L_i (i varying from 1 to 5) represents the known test loads, I_i the corresponding indication when the load on the NAWI is increased, and I'_i the corresponding indication when the load is decreased.

In order to draw the straight line characterizing the estimating linear model, use is made of the random variable ε_k , defined as follows:

$$\varepsilon_k = I_{kc} - aL_k \tag{4}$$

where the I_{kc} 's are the corrected indications and the L_k 's are the corresponding applied loads; a is the slope of the estimating model straight line.

To achieve on average a zero variation ε for optimizing the fitting of the estimating model, the expected value of ε_k is calculated and let to be equal to zero:

$$E[\varepsilon_k(a)] = E[I_{kc}] - a \cdot E[L_k] = 0 \tag{5}$$

From (5) the slope of the estimating model straight line is:

$$a = (\sum_k (I_{kc} + I'_{kc}) / (\sum_k L_k)) \tag{6}$$

In (6) use has been made of the unbiased average estimator (arithmetic mean) for the mathematical expectation operators appearing in (5):

$$E[I_{kc}] = (\sum_k (I_{kc} + I'_{kc})) / 9$$

$$E[L_k] = (2 \cdot (L_1 + L_2 + L_3 + L_4) + L_5) / 9$$

The first condition which the NAWI has to meet to pass the fast verification is that the corrected errors be within the in-service mpe's for the five test loads.

The further condition with which the NAWI has to comply is based on the strain-loading process: an unknown load L^* equal to 50 % Max or more is applied to the NAWI, then the corresponding indication I_U is noted; starting from this load a known test load ΔL , preferably of the same amount as 500 e, is applied to the NAWI: the new indication I_F is noted. The corrected indications (I_{Uc} and I_{Fc}) are then calculated. The situation is shown in Fig. 2; as indicated, the error that is likely to characterize the NAWI at the load $L^* + \Delta L$ is:

$$E_p = (I_{Uc} + \Delta I) - (L^* + \Delta L) = I_{Uc} + (I_{Fc} - I_{Uc}) - L^* - \Delta L \tag{7}$$

By using the estimating linear model $I_c = a \cdot L$, (7) can be written as:

$$E_p = [(a - 1)/a] I_{Uc} + (\Delta I - \Delta L) = [(a - 1)/a] I_{Uc} + (I_{Fc} - I_{Uc} - \Delta L) \tag{8}$$

By means of (8), the error at the load $L^* + \Delta L$ can be estimated: the NAWI passes the fast verification only if the E_p value remains within the mpe value corresponding to the load $L^* + \Delta L$ ($(I_{Uc}/a) + \Delta L$).

3.3 Statistical consideration of the estimating linear model

The error determined by (8) is based on an estimating model which makes use of a parameter a , based on the hypothesis that the NAWI's main source of error is due to its sensitivity properties and that, at least in the initial weighing range, other influence factors affecting the NAWI's accuracy balance each other (this is the meaning of (5)).

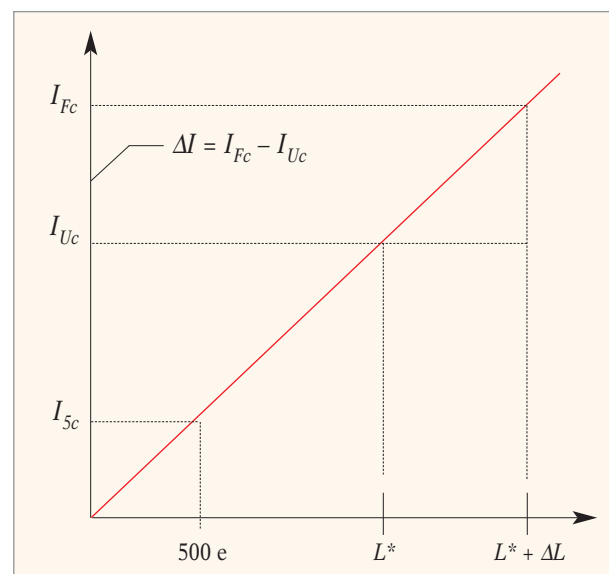

Fig. 2 The strain loading process

Thus (8) is in fact an estimate; for this reason it calls for a valuation of its reliability.

In order to do that, reckoning with constraint (5) a standard deviation estimate s_a could be defined as:

$$s_a^2 = E[(\varepsilon_k(a) - E[\varepsilon_k(a)])^2] = 1/8 \Sigma_1^9 (I_k - a \cdot L_k)^2 \quad (9)$$

Because of definition (4) the following can be written:

$$I_k = \varepsilon_k(a) + a \cdot L_k \quad (10)$$

From (10) the indication variance can be evaluated as:

$$s_I^2 = s_a^2 \quad (11)$$

because a and L_k are known values that are not subject to variations once they are determined.

From (8), in the following form:

$$E_p = [(a - 1)/a] I_{Uc} + (I_{Fc} - I_{Uc} - \Delta L)$$

due to the fact that the indication I_{Uc} is not determined but only extrapolated by the estimating linear model, the error variance can be written as:

$$s_E^2 = ((a - 1)/a)^2 \cdot s_I^2 + s_L^2 = s_I^2 \cdot \{1 + [(a - 1)/a]^2\} \quad (12)$$

Tchebicheff's Theorem [7] can help estimate the reliability of the error calculated by means of (8): indicating by E the "true" error and by k a constant, the probability that the error falls far from the estimated E_p by more than the quantity $k \cdot s_E$ is given by:

$$P\{|E - E_p| \geq k \cdot s_E\} \leq 1/k^2 \quad (13)$$

The criterion for considering the estimate (8) as reliable could be that the distance $k \cdot s_E$, defining the uncertainty of the estimate, be less than or equal to 1/3 mpe, i.e.:

$$k \cdot s_E \leq (1/3) \text{ mpe} \quad (14)$$

In (14) k has to be greater than or equal to 3 in order to ensure that:

$$P\{|E - E_p| \geq k \cdot s_E\} \leq 1/9 \quad (15)$$

i.e. that the probability that the true error E is far from the estimated error E_p by more than $k \cdot s_E$ is 11.1 % or less.

Thus when performing the strain-load test a NAWI passes the fast verification procedure if the estimated error E_p corresponding to the virtual applied load is within the mpe value, and $[(\text{mpe})/(3 \cdot s_E)] \geq 3$. If the latter condition is not verified, then a full verification procedure according to the relevant technical standards has to be performed.

3.4 Form for the fast verification procedure

To better summarize the strain-load fast verification procedure, a Verification Form example is given in Annex 1 (opposite).

4 A worked out example

In order to establish whether the strain-load fast verification procedure satisfactorily fulfills the purpose for which it is intended, an experiment was prepared with the aid of a NAWI manufacturer, the firm "Adriano Gomba & C. S.a.s.", based in Naples.

A NAWI was first calibrated as best as possible, to keep it within the mpe's. The strain-load fast verification procedure was then applied: the results are shown in Annex 2 (page 14).

Then the error at the maximum virtual load was determined in the classical way by means of test loads. The former error (estimated) was found to be - 0.27 kg at a 400 kg load; the latter error (determined) was found to be - 0.22 kg at the same 400 kg load.

5 Acknowledgement

The author wishes to thank the "Adriano Gomba & C." management staff, Mr. Massimo Cappelli and Mr. Mario De Rosa, as well as Mr. Vincenzo Anastasio, Quality Management System Supervisor and Mr. Sabato Rea, NAWI Head Technician, for their courtesy in providing a type approved NAWI and technical assistance to perform the test described in section 4. ■

References

- [1] EN 45501: *Metrological Aspects of Non Automatic Weighing Instruments*
- [2] OIML R 111: *Weights of classes E₁, E₂, F₁, F₂, M₁, M₂, M₃*
- [3] OIML R 47: *Standard weights for testing of high capacity weighing machines*
- [4] NIST Handbook 44: *Specifications, Tolerances and other technical Requirements for Weighing and Measuring Devices*
- [5] Aurel Millea, *Some fundamental concepts in metrology* - OIML Bulletin No. 91, June 1983
- [6] Council Directive on the Harmonization of the laws of the European Member States on Non Automatic Weighing Instruments 90/384/EEC
- [7] Sergio Benedetto, Ezio Biglieri, *Teoria della probabilità e delle variabili casuali - 7*, Collana "Quaderni di Elettronica", Ed. Boringhieri Torino

Annex 1 Fast verification data registration form

Strain-load fast verification procedure

NAWI's data: Manufacturer _____
 Model _____
 Serial No. _____
 Max _____
 (Max₁, Max₂, Max₃) _____
 Interval d, e _____
 (e₁, e₂, e₃) _____

Step 1

Zero error E₀: _____

	Load L _i	Ind ↑	Ind ↓	I _c = Ind ↑ - E ₀	I' _c = Ind ↓ - E ₀	Corr. Error↑	Corr. Error↓
1							
2							
3							
4							
5							

$\Sigma L = 2 \cdot (L_1 + L_2 + L_3 + L_4) + L_5 =$ _____
 $\Sigma I_c =$ _____
 $\Sigma I'_c =$ _____

Check as appropriate:

- Corrected errors are all within maximum permissible in-service error values ⇒ **GO ON TO STEP 2**
- One or more corrected errors are out of the maximum permissible error values ⇒ **NAWI FAILS**

Step 2

Estimating linear model slope: $a = (\Sigma I_c + \Sigma I'_c) / \Sigma L =$ _____

Indication variance s_i²:

Load L	aL	I _c	I _c - aL	(I _c - aL) ²	I' _c	I' _c - aL	(I' _c - aL) ²

$s_1 = \Sigma(I_c - aL)^2 =$ _____ ; $s_2 = \Sigma(I'_c - aL)^2 =$ _____
 $s_i^2 = (s_1 + s_2)/8 =$ _____ ; $s_i =$ _____

Corrected indication at the strain load: I_{Uc} = _____
 Known test load after the strain load: ΔL = _____
 Corrected final indication: I_{Fc} = _____
 Virtual applied load: L_V = I_{Uc}/a + ΔL = _____
 Maximum permissible error at L_V: mpe = _____
 Error estimate at L_V: E_p = ((a - 1)/a) I_{Uc} + (I_{Fc} - I_{Uc} - ΔL) = _____
 Standard deviation of the error estimate: s_E = s_i(1 + ((a - 1)/a)²)^{1/2} = _____
 mpe/(3s_E) = _____

- Is (E_p ≤ mpe **and** (mpe/(3s_E)) ≥ 3)? ⇒
- YES: NAWI passes**
 - NO: Apply full verification procedure according to EN 45501**

Annex 2 overleaf ▶▶▶

Annex 2 A worked out example of the strain-load fast verification procedure

Strain-load fast verification procedure

NAWI's data: Manufacturer	Gomba
Model	SG
Serial No.	
Max	600 kg
(Max ₁ , Max ₂ , Max ₃)	
Interval d, e	0.2 kg
(e ₁ , e ₂ , e ₃)	

Step 1

Zero error E₀: 0

	Load L _i	Ind ↑	Ind ↓	I _c = Ind ↑ - E ₀	I' _c = Ind ↓ - E ₀	Corr. Error↑	Corr. Error↓
1	20	19.98	19.98	19.98	19.98	- 0.02	- 0.02
2	40	39.96	39.98	39.96	39.98	- 0.04	- 0.02
3	60	59.94	59.92	59.94	59.92	- 0.06	- 0.08
4	80	79.92	79.92	79.92	79.92	- 0.08	- 0.08
5	100	99.92		99.92		- 0.08	

$\Sigma L = 2 \cdot (L_1 + L_2 + L_3 + L_4) + L_5 = 500 \text{ kg}$

$\Sigma I_c = 299.72$

$\Sigma I'_c = 199.8$

Check as appropriate:

- Corrected errors are all within maximum permissible in-service error values ⇒ **GO ON TO STEP 2**
- One or more corrected errors are out of the maximum permissible error values ⇒ **NAWI FAILS**

Step 2

Estimating linear model slope: $a = (\Sigma I_c + \Sigma I'_c) / \Sigma L = 0.99904$

Indication variance s_i²:

Load L	aL	I _c	I _c - aL	(I _c - aL) ²	I' _c	I' _c - aL	(I' _c - aL) ²
20	19.98	19.98	0	0	19.98	0	0
40	39.96	39.96	0	0	39.98	0.02	0.0004
60	59.94	59.94	0	0	59.92	- 0.02	0.0004
80	79.92	79.92	0	0	79.92	0	0
100	99.90	99.92	- 0.02	0.0004			

$s_1 = \Sigma(I_c - aL)^2 = 0.0004;$ $s_2 = \Sigma(I'_c - aL)^2 = 0.0008$
 $s_i^2 = (s_1 + s_2)/8 = 0.00015;$ $s_i = 0.012$

- Corrected indication at the strain load: $I_{Uc} = 299.96$
- Known test load after the strain load: $\Delta L = 100$
- Corrected final indication: $I_{Fc} = 399.98$
- Virtual applied load: $L_V = I_{Uc}/a + \Delta L = 400.25$
- Maximum permissible error at L_V: $mpe = 0.6$
- Error estimate at L_V: $E_p = ((a - 1)/a) I_{Uc} + (I_{Fc} - I_{Uc} - \Delta L) = - 0.27$
- Standard deviation of the error estimate: $s_E = s_i(1 + ((a - 1)/a)^2)^{1/2} = 0.012$
 $mpe/(3s_E) = 16.67$

- Is $(E_p \leq mpe \text{ and } (mpe/(3s_E)) \geq 3) \Rightarrow$ **YES: NAWI passes**
- NO: Apply full verification procedure according to EN 45501**



TRAINING

Accreditation of training in legal metrology

KERRY MARSTON, Regional Training Coordinator, APLMF

In recent years, the Australian technical training system has undergone a massive change in focus after Australian industry expressed concern that the courses being offered no longer developed the understanding and skills in graduating students that were required by industry. In effect, the training courses were not in tune with the current needs and requirements of industry, a situation intolerable for any industrialized nation. The response was the development of a method of training called Competency Based Training or CBT which is able to identify and respond to the training needs of any industry.

The design of CBT curriculum and programs is such that they will ensure that the student acquires the competency of understanding and skills to the appropriate standards that have been specified by the industry. Assessment is designed to enable the student to demonstrate that they have achieved the understanding and skills expressed as the competencies required by industry.

To guarantee that these courses meet the highest standard possible, the curriculum, course materials, training facilities and trainers are all rigorously assessed by both technical and educational experts. If successful, the training course will be given national accreditation and successful participants will qualify with nationally accepted credentials.

This accreditation of trainers and training materials is very similar in principle to the accreditation of a laboratory to ensure that it meets a certain standard*. Such accreditation can then be used to select a laboratory for a particular task with confidence in the standard and quality of the work to be provided.

The movement towards globalization and the elimination of technical barriers to trade both internationally and regionally has created an urgent need for mutual confidence and measurement consistency between national legal metrology systems. As a result, both bilateral and multilateral mutual recognition arrangements are being developed between trading partners.

* BIML note: Discussions have taken place within the OIML as to whether the word "accreditation" is most appropriate in the context of training. The use of "validation" or "certification" has been suggested, however no final decision has yet been made.



Fig. 1 APLMF industry training course on the requirements for pattern approval, Ottawa, Canada, 1999

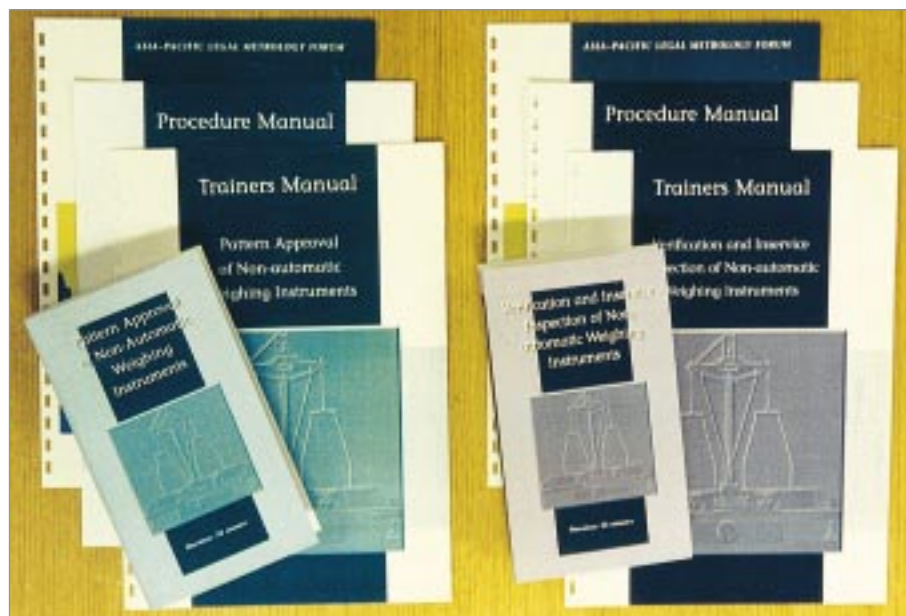

Fig. 2 CBT training packages developed by the APLMF to assist in the implementation of OIML R 76

This is all being strongly supported by the OIML's long pursuit of international metrological harmonization. In fact the fundamental importance of OIML Recommendations and Documents cannot be overstated as mutual recognition arrangements develop throughout the world.

To support this fundamental need, OIML Recommendations are only published after extensive research and very broad international consultation by the Technical Committee. Developing and producing OIML Recommendations and Documents is only the first step in a process to ensure that they are used effectively. To assist in this process many OIML Recommendations are now being supported by a set of detailed test procedures.

However, the satisfactory implementation of any OIML Recommendation depends on the development of similar interpretations and understandings of the Recommendation. Along with this, the same level of technical competence in carrying out the evaluation and verification test procedures needs to be developed throughout the many different systems around the world. This competence can only be achieved through joint discussion and personnel interaction as a function of training. Therefore, training has to cover the same content, ensure that the participants have achieved the same outcomes, and be presented by highly qualified and professional trainers in suitable training facilities.

Currently, countries and regional organizations are having to develop their own training packages and training courses in order to implement a Recommendation. This can be a very expensive and time-consuming task. Consequently, many countries and organizations

are seeking existing training packages to assist them in training their staff so that they can satisfactorily implement OIML Recommendations.

At present there is no way of judging whether or not any of these training packages provide a sound basis on which to build the understanding and skills necessary to implement the Recommendation to meet OIML requirements envisaged by the Technical Committee. Accreditation similar to the Australian model would mean that the training materials and trainers have to go through a rigorous appraisal by experts who would ensure that the criteria and requirements set by the OIML have been met.

To do this, the OIML would need to set out the style, required components and criteria that must be met in order to receive OIML accreditation. The accreditation of any training materials should focus on the assessment of the competency standards and content of courses to ensure:

- the educational standard of the materials;
- that the materials are technically correct;
- the use of appropriate international metrology language;
- relevance to industry and the community;
- that learning outcomes and content are appropriate to the technical skills required;
- that assessment methods are included and appropriate; and
- that the materials are easy to follow and can be used in a variety of situations.

Such a proposed process for OIML accreditation of training materials and courses based on OIML Recommendations would ensure quality training. Courses accredited under the OIML principles could then be listed on an international register within the OIML Bulletin and on the OIML web site (www.oiml.org) and be recognized internationally as OIML accredited courses.

The quality and effectiveness of any training course is also only as good as the appropriateness of the facilities and equipment being used, the communication and training skills of the trainer and the relationship between trainer and student. To guarantee the effectiveness of the training course there is also a need to accredit organizations and personnel as training providers.

Based on the above concept, countries, organizations and industries seeking training courses and/or a training provider would be able to select from this register. This would give them confidence that whatever

they select and use will be of a high standard and will assist them to implement OIML Recommendations to an appropriate level to meet international requirements.

It should also be mentioned here that a training course can only make personnel task-ready. To ensure competence, confidence and the mutual recognition of test results requires experience and other tools such as intercomparisons between laboratories. Training, however, must be one of the initial steps and as such be recognized as an essential part of the mutual recognition equation.

It is therefore of paramount importance to ensure that any available training and training resources meet a high standard which has been established and set by the OIML. To ensure the highest possible standard, the available training and training resources should be of a high educational standard as well as of a high technical standard. ■



Fig. 3 APLMF train the trainer course on the verification of nonautomatic weighing instruments, Bandung, Indonesia, 1999

For further discussion on this issue contact:

Kerry Marston - Regional Training Coordinator, APLMF
 National Standards Commission (NSC)
 PO Box 82, North Ryde, NSW 1670, Australia
 Tel: +61 2 9888 3922 - Fax: +61 2 9888 3033
 E-mail: kmarston@nsc.gov.au



SANCTIONS

Penalties for offences committed under legal metrology regulations in Germany

FRIEDRICH HOLLINGER, Head of Administration Division,
Verification Authority of Rhineland-Palatinate, Germany

The regulations governing legal metrology in the Federal Republic of Germany concern both regulatory law (to which trade and industry are subject), and protective rights of the consumer. The former regulates the correctness of measurements in commercial transactions, the latter the movement of goods between enterprises and the sale of goods to consumers. Of prime importance is the fairness of legal transactions, and thus of competition; the objective is to ensure that neither of the parties involved in commercial transactions (buyer and seller) suffers financial prejudice or other losses due to inaccurate measuring instruments or as a result of inadequate or excessive filling of prepackages.

These concerns are of particular significance in the age of market globalization. The underlying intention is that the buyer of goods and measuring instruments can be totally sure that any products bought have the specified characteristics and will thus serve the purpose for which they were bought, irrespective of the country of origin. In particular in trade within free trade areas (such as the European Union), a structured exchange of goods without special border control measures is conceivable, but is only possible if the relevant regulations are effectively complied with in the producing country.

In some fields (e.g. in-plant verification of weighing instruments, prepackages) where regulations have been harmonized within the European Union, confidence in the controls of the producing country is sufficiently high that checks are only carried out in the receiving countries if there are reasonable grounds to suspect that an offence under the relevant provisions has been committed. This means that barriers to trade have been removed.

A prerequisite for such a degree of confidence has been that the level which the producing countries have reached in the implementation of the relevant regulations and their control is comparable to that reached in the country where the product is brought to market.

It is thus the task of the competent authority to check whether the desired level has in fact been reached by all those involved in commercial transactions and whether the relevant regulations are observed.

In Germany the legislator has given the competent authorities two tools to exercise these controls: preventive measures (e.g. verification of the measuring instruments) and a repressive system (including, for example, inspection of prepackages).

This means that, within the scope of market surveillance, the verification officers carry out *in situ* tests of measuring instruments (subsequent verification) and supervise compliance with other regulations (e.g. regulations governing contents quantities).

Market surveillance and the detection of offences has made it necessary for the competent authorities to be in possession of the legal means that make it possible for them to fulfil their tasks correctly.

Regulations governing supervisory measures

Under German verification law regulations, this has been ensured by the provisions of section 16 of the Verification Act. Both the body to which supervisory powers have been transferred and those subject to supervision have been given the rights and obligations described below:

Rights:

- to enter property, operational premises and businesses. This right is restricted in that it is limited to regular operating and working hours;
- to carry out examinations and inspections;
- to take samples; and
- to inspect business records.

Obligations:

- to furnish information;
- to accept supervisory measures;
- to support the supervisory bodies by indicating the rooms in which work subject to supervision is carried out, to present documents, to open rooms and containers, and to make sampling possible; and
- the importer of prepackages and containers must accept examinations and fulfil his obligation to furnish information.

Transfer of the above rights has enabled the competent authorities to ensure efficient supervision of the entire market and to detect offences.

The detection of market irregularities is not, however, sufficient to ensure compliance with the relevant regulations as is desirable on the market. To achieve this, the competent authorities must be given the required regulatory tools. This requirement has been met by classifying offences under the verification law regulations as administrative offences.

Penalties

As a result of the above classification, the bodies concerned are in a position to instigate proceedings for administrative offences against companies and individuals who infringe regulations under verification law.

Every administrative offence uncovered on site on the territory of a Federal state is recorded on a form and reported to the verification board concerned, which initiates and follows through proceedings. These proceedings can be concluded by the imposition of a cautionary fine or by fixing an administrative fine. They are not, however, penalties: their purpose is to enforce certain regulations, and they are thus a warning to those concerned to observe the relevant rules and prohibitions - an appeal which involves the imposition of sanctions and whose effects are, therefore, felt.

Cautionary fines (which range from 10 DM to 75 DM) may be imposed only in the case of minor administrative offences; more severe offences are punished by an administrative fine.

The amount of the administrative fine (which depends on the nature and seriousness of the offence) is taken from one of the lists of offences punishable by fines, which have been drawn up by the verification boards of the Federal states and which are applied nationwide. The stated amount is imposed only in cases of negligence and in the case of deliberate acts the amount is doubled.

The highest individual administrative fine is 20 000 DM, but this amount may be exceeded if the individual concerned derived economic benefit from the offence: the fine must be at least equal to the "profit", even if the upper limit fine is exceeded. These sanctions therefore aim to ensure that unlawful acts do not generate benefit.

Incidental consequences

Parallel to fixing the administrative fine, the authority may order incidental consequences. These are independent of the seriousness of the offence and serve to discourage future offences. The following measures are concerned:

Forfeiture

Within the framework of forfeiture, the instrument owner forfeits his or her ownership interests in the objects (e.g. measuring instruments) or the title interests (e.g. claims, bank balances). Return of the objects and restoration of the title is not possible: the ownership interests permanently pass into the hands of the State.

Wreckage

Objects are destroyed so that future offences are rendered impossible.

Transfer of the excess proceeds

The enterprise must transfer the proceeds gained even if the offence was committed by a staff member without the enterprise's knowledge.

Compensation

If, for legal reasons, the authority refrains from issuing an administrative order or imposing a fine although it has been established that the act constitutes an offence, orders can be given to the effect that the offender has to pay an amount of compensation.

Appeal against penalties

The party concerned has the right of appeal against the regulatory measures imposed (administrative order imposing a fine or order of incidental consequences). An appeal against the measure taken lodged with the authority obliges the latter to recheck the matter. If the appeal is disallowed, the files are submitted to a court and the case is heard in open court. The proceedings are then concluded by a sentence.

Types of offence and penalties

Despite the great variety of offences, the majority fall under six fields, defined by the respective protection aim of the regulation and the seriousness of the offence. The offences concerned are the following:

1 Offences under regulations governing the putting into circulation of measuring instruments

These are offences under regulations that guarantee to the buyer (or user) of the measuring instrument that its characteristics comply with those specified in the approval certificate issued by the PTB, Braunschweig, and that the instrument can thus be verified, because use in, and holding in readiness for, commercial transactions are permitted only in that case.

In the case of measuring instruments which, on the basis of the relevant regulations, may be put on the market after having been verified by the manufacturer, the buyer is to be guaranteed that the former has taken all necessary measures to fulfil the legal requirements for its use in commercial transactions.

The number of offences in this area is small. However as these offences are of fundamental importance, the fines imposed are in the upper range.

2 Offences with respect to the use and holding in readiness of measuring instruments

This area is of great significance for various reasons. Many of these measuring instruments are used in commercial transactions to directly measure goods for the customer (for example in shops, at petrol stations and for the delivery of domestic heating fuel oil).

In the field of prepackages, measuring instruments are used both during production and as control instruments for the supervision of correct filling. Measurement of goods here is indirect, since the customer is not present at the place where the measuring instrument is used.

In addition, measuring instruments are used in environmental protection (for example exhaust gas analyzers for CO and diesel) and for traffic safety (for example tyre gauges).

As the measurement results are of economic importance and also have a protective function, the legislator and German ordinance issuing bodies oblige measuring instrument owners to submit them to the verification office for a metrological test prior to the expiry of the validity of the verification. If those responsible for this fail to meet their obligations, they accept that the measurement results do not reflect the actual conditions and that a loss can be incurred either by their customers or by themselves.

This means that, just in this field, the situation may arise that the measuring instrument owner derives unjustified economic benefit because of non-compliance with the regulations under verification law. This benefit is to be "skimmed off" within the scope of the administrative offence proceedings.

The Verification Authority of Rhineland-Palatinate recently followed such an administrative offence procedure against certain public utility companies, who had omitted to remove a large number of water, electricity and gas meters from the supply network in due time prior to the expiry of the validity of the verification. These companies would have saved verification fees and meter removal/new installation costs of up to 32 000 DM, but this benefit was confiscated by the Verification Authority by the imposition of an administrative fine in excess of that amount, thus ensuring that the companies concerned did not gain any advantage over competitors who had removed their meters in time.

In the case of minor offences committed by small companies (e.g. market traders), the fine must, of course, be at the lower level of the range (for example, 100 DM to 200 DM).

3 Offences as regards observance of the regulations governing the net contents of prepackages, and

4 Offences as regards observance of the regulations governing prepackage labeling

These two areas can be dealt with jointly, as they have much in common.

European Union regulations protect the consumer (who can neither observe nor check the production process of prepackages) against inadmissible inadequate filling and - to maintain market transparency - against inaccurate labeling.

Inspections by the verification authorities at the manufacturer's and in trade are, therefore, possible and prepackages from both domestic and foreign production may be checked. Both foreign and domestic producers are thus protected against competitors who do not comply with the provisions and thus gain a financial (or other) advantage.

As inadequate filling directly affects the consumer, the fines imposed for this offence must be higher. However, offences under the labeling regulations can also be punished by high fines, in particular when the EEC mark "e" has been applied to the prepackages.

5 Offences under regulations governing the installation and use of measuring instruments

The relevant regulations directly concern the instrument user, who may cause the customer or him/herself considerable damage if the instrument is not properly installed and used.

An offence will, of course, be punished only if the customer suffers losses. The administrative fines imposed in this area decisively depend on the damage to the third party.

6 Offences under the prohibition to weigh loose goods "gross for net"

In a large number of cases the verification authorities note that when loose goods are sold, the mass of the wrapper is added to the quantity of the goods sold when the value of the goods is determined with the aid of a measuring instrument.

Despite the fact that the weight of the wrapper is usually negligible, the global loss borne by the consumer is not insignificant: a figure of 15 000 000 DM is put forward for Germany.

It is therefore important that compliance with these regulations is supervised and offences are consistently proceeded against. An administrative fine of DM 500 has therefore been fixed for first offenders.

Conclusion

The above shows that regular market surveillance and a consistent line of action are required to protect both the consumer and companies against unfair practices and unfair competition. Only then will it be possible to offer all national and foreign competitors conditions and chances that are equal from the verification law point of view.

From the verification authorities' position, the system of preventive and repressive measures has proved its worth and will continue to be applied in the future, in the hope that the number of offences will decrease and that free global trade will be possible with as few State interventions as possible. ■

The author will be pleased to answer any questions:

Friedrich Hollinger,
Head of Administration Division,
Verification Authority of Rhineland-Palatinate,
Bad Kreuznach,
Germany

Fax: +49 671 73475
E-mail: eichdirektion.rpl@t-online.de

SOFTWARE

WELMEC activities towards harmonized software requirements and software examination for measuring instruments under legal control

ROMAN SCHWARTZ and ULRICH GROTTKER, Physikalisch-Technische Bundesanstalt (PTB), Braunschweig, Germany



Revised lecture given at the
OIML Seminar on Software

1 WELMEC - A short introduction

In 1990 fifteen EU countries and three countries in the European Free Trade Association (EFTA) signed a Memorandum of Understanding (MoU) which formally established WELMEC as the (Western) European Legal Metrology Cooperation. The MoU is of an exclusively recommendatory nature, i.e. WELMEC is a free cooperation which seeks to reach agreement on a range of issues of mutual interest and wide importance [1]. Since 1995, five countries from central Europe have joined WELMEC as Associate Members.

The principal aim of WELMEC is to establish a harmonized and consistent approach to legal metrology in the light of a number of important developments, e.g. the increasing international trade in measuring instruments. Among others, two of the major objectives according to the WELMEC MoU are:

- To develop and maintain mutual confidence between legal metrology services in Europe; and
- To achieve and maintain the equivalence and harmonization of legal metrology activities, taking into account the relevant guidelines.

WELMEC has links with other bodies, for example the European Commission (EC), the European Free Trade Association (EFTA), the OIML, and the European Organization for Testing and Certification (EOTC). There are also links to "Corresponding Organizations", e.g. the Asia Pacific Legal Metrology Forum (APLMF)

and European organizations of manufacturers and industries.

The current activities of WELMEC are particularly focused on the completion and ongoing operation of the single European market. At the moment there are eight Working Groups supporting the WELMEC Committee, for example:

- WG 2: Directive Implementation 90/384/EEC (Non-automatic Weighing Instruments);
- WG 7: Software; and
- WG 8: Measuring Instruments Directive (MID).

2 The necessity for harmonized software requirements in legal metrology

Some examples are given to illustrate that software is also of increasing importance in legal metrology and requires an adequate and harmonized approach for treatment at type approval and verification.

Example 1

The metrological performance of measuring instruments is increasingly determined by the software processing the raw data after A/D conversion up to the digital output of the instrument.

Consequence: The software that processes the raw data on their way to the digital output, including the calibration and configuration parameters, must be protected against unauthorized access.

Example 2

Measuring instruments nowadays offer a great variety of different and complex functions. Menus, e.g. in graphic displays, offer the user a mixture of legally relevant functions and functions outside the scope of legal metrology.

Consequence: The software of complex measuring instruments should be designed in such a way that the legally relevant functions are separated from the other functions so that only the legally relevant program part needs to be protected.

Example 3

Many measuring instruments nowadays are capable of being integrated in networks, meaning that the communication and exchange of data or information (or even programs) over large distances is simple and fast.

Consequence: The approved software, the approved metrological and technical functions and the legally relevant data produced by the approved and verified measuring instrument must be protected by appropriate means against corruption and misuse. In addition, they must be capable of being identified as authentic software and authentic data by the user and the inspection personal.

The criteria for developing reasonable and adequate software requirements in legal metrology are:

- As much protection of the consumer against corruption of measurement results as necessary, taking into account the risk of fraud;
- As little restriction as possible with regard to the flexibility of modern software-controlled measuring instruments and the comfort for the user; and
- Clear guidelines and instructions for both manufacturers (programmers) of measuring instruments and examiners (inspectors) of Notified Bodies so that technical uncertainties and unequal treatment of applicants can be avoided.

3 Experiences with the WELMEC software guide for weighing instruments

It has been the experience with the European Directive 90/384/EEC [2] for non-automatic weighing instruments (NAWI) that the essential requirements for NAWI's needed a uniform interpretation with regard to software, in order to avoid an unequal treatment of customers by the various European Notified Bodies. The result of respective discussions in WELMEC WG2 was the publication of the WELMEC Guide 2.3 [3] in 1995. It was initially restricted to free programmable computers forming part of non-automatic weighing instru-

ments, e.g. PC-based indicators or point-of-sale devices. Since 1997 the guide WELMEC 2.3 is also applied to automatic weighing instruments and it is partly applied to software stored in EPROM's. WELMEC 2.3 deals with:

- Definition of important terms used in the guide (terminology); and
- Four software requirements concerning the aspects:
 - *protection of software against intentional changes (corruption);*
 - *separation of software in one protected part covering the legally relevant functions of the measuring instrument and another part being separated from the protected part by a protective software interface;*
 - *identification of software at verification/inspection; and*
 - *documentation of software at type approval.*
- Recommendations concerning the information about software to be provided in type approval certificates and test certificates; and
- Recommendations concerning software test reports.

In 1997 WELMEC 2.3 was officially amended by a checklist intended to support software examination at type approval.

The experiences with the WELMEC software guide for weighing instruments since its publication in 1995 can be summarized as follows:

- The guide was a first step to harmonizing software examination in Europe by fixing the levels for:
 - *Software protection against corruption*

According to the definition given in 5.3.1, the "middle" software protection level has been chosen for weighing instruments, i.e. the legally relevant software shall be protected against intentional changes with simple common software tools (text editors). Software protection against corruption with special sophisticated software tools (debuggers, hard disc editors or software developing tools) is not required.

- *Software examination at type approval*

According to the definition given in 5.3.2, the "middle" software examination level has been chosen for weighing instruments, i.e. in addition to the normal type examination tests ("hardware tests" of the measuring instruments, e.g. according to OIML R 76 [4]) the software is examined on the basis of an additional description of the legally relevant software supplied by the manufacturer. This functional description must not be mixed up with the program listing of the source code which is not examined at "middle" level. It is verified, however, whether the documented functions are com-

plete and consistent. For PC-based instruments or open measuring systems with possible user access, practical tests (spot checks) with the program are conducted in order to check, for instance, whether all protection measures are effective and whether commands and the identification of the legally relevant software operate as documented.

- *Degree of software conformity and software identification*

According to the definition given in 5.3.3, the “low” conformity level has been chosen for weighing instruments, i.e. the implemented software of each individual instrument shall be in conformity with the approved functional description (documentation) of the legally relevant software. There is no bit-to-bit identity required for the implemented code, i.e. in case of minor corrections to the source code a new legal software identification would not be required if the functionality of the measuring instrument and the characteristics of the legally relevant software remained unchanged compared to the approved software documentation. The Notified Body for type approval must, however, be informed about *any* changes of the legally relevant software and it is the decision of the Notified Body whether these changes require additional approval and a new legal software identification.

- On the whole the guide serves the criteria for reasonable and adequate software requirements mentioned in chapter 2. In particular it combines a reasonable protection level in the consumer’s interest with general rules that leave sufficient flexibility for manufacturers and software developers.
- It offers the possibility for manufacturers and software houses to receive test certificates for approved software modules. There is a considerable interest in receiving such test certificates. Since 1995 the PTB, for instance, has issued 32 test certificates for software modules on the basis of WELMEC 2.3.
- There is still some uncertainty at Notified Bodies about software examination because there is still little experience in that field. In addition, software is still considered to be a rather difficult and complex issue for the normal test engineer who does not have a special qualification. Therefore, on the one hand, training courses and seminars seem to be advisable to overcome the understandable reserve; on the other hand, some effort has still to be made by the legislators to work out clear, well understandable and sufficiently detailed software requirements and software examination procedures.

4 WELMEC Working Group 7 “Software”

Based on experience with the WELMEC Guide 2.3 for weighing instruments, and due to the growing importance of software in legal metrology, the new WELMEC Working Group 7 “Software” started its work in 1996 as the successor to the former WG7 on Peripheral Equipment, Interfaces and Microcomputers.

The scope of the new WG7 “Software” is:

- To harmonize type approval practice with respect to the software of measuring instruments under legal control;
- To develop software guidelines (general and specific ones) for the different categories of measuring instruments covered by the Measuring Instruments Directive (MID) [5], taking into account also new technologies; and
- To make the specific software guides detailed enough to enable a manufacturer to build his software in conformity with the MID.

For measuring instruments that are covered by the MID, refer to Table 1 under 5.4.

At the moment WELMEC WG7 consists of Members from 11 Western European countries, Associate Members from 2 Central European countries and representatives from 6 European Associations and Organizations: CECIP (Manufacturers of Weighing Instruments), CECOD (Manufacturers of Petrol Measuring and Distributing Equipment), FACOGAZ (Gas Meter Manufacturers), MARCOGAZ (Natural Gas Industry), CITEF (Electricity Meter Manufacturers) and EURELECTRIC/UNIPEDA (Electrical Energy Industry). The following European Associations and Organizations have also been invited to participate in future meetings: AQUA (Water Meter Manufacturers), EUREAU (Water Supply Association), EHMA (Heatmeter Manufacturers), EUROHEAT&POWER (District Heating and Cooling, Combined Heat and Power), ANEC (Consumer Representation in Standardization) and BEUC (Consumers Organization).

There are also links to corresponding Working Groups, e.g. the Canadian Software Working Group.

5 The new WELMEC Software Guide based on the MID

In 1999 WELMEC WG7 finalized its first software guide, the WELMEC Guide 7.1 “Software Requirements on the Basis of the Measuring Instruments Directive”. After approval by the WELMEC Committee this general software guide has recently been published [6] and it is

now also available on the WELMEC web site www.welmec.org/publications.

WELMEC Guide 7.1 is an attempt to make legal metrologists aware of the fact that only testing the metrological performance of an instrument without especially taking care of the software controlling this instrument is in many cases no longer adequate. This is especially the case for modern, microprocessor-controlled or even computer-based measuring instruments, as it is predominantly the software and its integrity that determines the metrological properties and reliability of an instrument. The Guide is intended to demonstrate the approximate direction and important aspects of software examination rather than to detail specific software requirements for each category of measuring instruments. It is, therefore, intended to be successively amended by specific annexes or supplementary guidelines that will contain software requirements, checklists, examples of acceptable technical solutions and other recommendations for each kind of measuring instrument. The major parts of WELMEC guide 7.1 are presented below.

5.1 Terminology

The guide contains a summary of the most fundamental terminology used. Examples are:

- Program code (source code, executable code);
- Legally relevant software (e.g. legally relevant program parts, see Fig. 1);

- Changes to software (unintentional and intentional changes);
- Protection of software (e.g. audit trail, event counter, event logger);
- Interfaces (e.g. protective software interface); and
- Data security (authenticated program, checksum, electronic signature, legal software identification.)

5.2 Essential software requirements

The guide contains 11 essential software requirements that are directly derived from the essential requirements of the MID and cover the following five subjects:

- Software design and structure
Example: "The legally relevant software shall be designed in such a way that it is not inadmissibly influenced by other software."
- Software protection
Example: "Legally relevant programs and data shall be protected against corruption or intentional changes by unauthorized persons."
- Software conformity
Example: "For the verification of conformity an identification of the legally relevant software and suitable instructions shall be available."
- Testability
"The functionality of the instrument shall be testable."

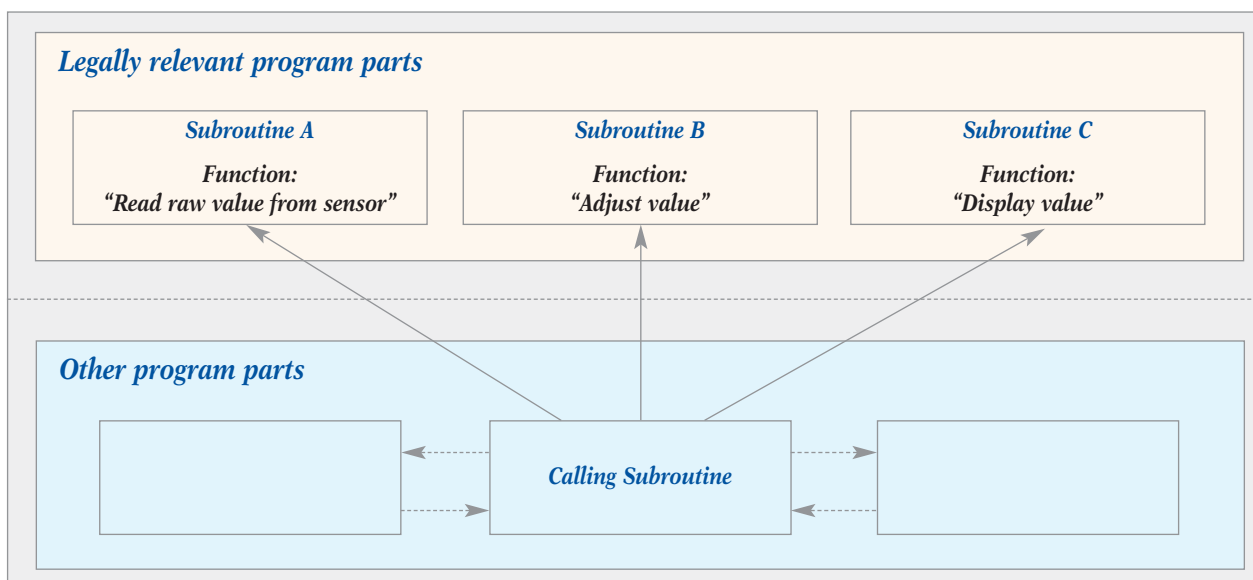

Fig. 1 One example of legally relevant subroutines realizing legally relevant functions, and other program parts being separated. Here the legally relevant parts of a program system are realized as subroutines (above the dividing line). Additionally there are subroutines that are not legally relevant (below the line). The arrows show which subroutine is called by another (tip of the arrow) and which subroutine is calling. Instead of subroutines, the components of the program code can also be formed by complete executable programs that call each other via the operating system.

- Documentation for type approval
"The legally relevant software, including its hardware and software environment, shall be suitably documented."

5.3 Definition of levels

Three levels are defined for each of the following criteria that have an impact on the software treatment of a measuring instrument:

- The strength of *protection of the software* against changes, depending on the risk of fraud;
- The intensity of *examination of the software* at type approval; and
- The *degree of conformity* between the software implemented in a verified instrument and the approved software.

5.3.1 Software protection levels

The software protection levels are defined as follows:

- Low:* There is no protection of the software against intentional changes required.
- Middle:* The legally relevant software is protected against intentional changes with simple common software tools (text editors).
- High:* The legally relevant software is protected against intentional changes with special sophisticated software tools (debuggers and hard disc editors, software developing tools) i.e. protection level according to the state of the art in data security, e.g. for financial transactions.

5.3.2 Software examination levels

The software examination levels are defined as follows:

- Low:* The software functions are verified by a normal type examination test ("hardware test"). There is no special software documentation required in addition to the normal documentation supplied by the manufacturer. For some technical features that are not covered by type examination tests (e.g. the protectiveness of interfaces) a declaration by the manufacturer is accepted that the software controlling the measuring instrument to be type approved does fully comply with the documentation supplied and that there are no functions other than the documented ones.

Middle: In addition to the normal type examination tests (see "Low") the software is examined on the basis of a description of the software functions supplied by the manufacturer (additional software documentation). It is verified whether the documented functions are complete and consistent.

High: In addition to the normal type examination tests and the examination of the software documentation (see "Low" and "Middle") the legally relevant software is tested using its source code. The subject of the code examination can be e.g. the realization of an algorithm, the filtering of the input via an interface or whether the software separation is realized correctly.

5.3.3 Degree of software conformity

The conformity levels are defined as follows:

- Low:* The implemented software of each individual instrument is in conformity with the approved **documentation**. Regardless of minor corrections of the source code the functionality remains identical to this documentation.
- Middle:* The implemented software of each individual instrument is in conformity with the approved **documentation**. Regardless of minor corrections of the source code the functionality remains identical to this documentation. In special cases depending for instance on the technical features (see 5.5), a **part of the legally relevant software** may be defined and fixed at type approval, which shall be **identical** to the implemented software of each individual instrument.
- High:* The **entire software** of each individual instrument is **identical** to the approved software.

5.4 Proposal for the assignment of levels

Table 1 contains a proposal for the assignment of levels to the different categories of measuring instruments covered by the MID. Further subdivision of the categories may turn out to be necessary in the course of the work of WELMEC WG7. A final proposal for an assignment will not be given before enough experience with the guide has been gathered and an agreement between all Working Group members has been reached. The differentiation of the risk of fraud will be based on the subjective assessment of respective experts rather than on objective criteria. Possible criteria are given in [6, 7].

Table 1 Proposal for the assignment of levels, as defined in 5.3, for different categories of measuring instruments

Category	MID Annex	Risk of fraud	Software protection level	Software examination level	Degree of software conformity
Supply to customer by mains	MI-001, MI-002, MI-003, MI-004	middle	middle	middle	middle
		high	high	middle	middle
Commercial transactions/services	MI-005, MI-006, MI-007, MI-009	middle	middle	middle	low
		high	high	middle	middle
Evidential measurement	MI-010	-	high	high	high
Environment, safety, health	MI-011	middle	middle	middle	low

MID Annexes:

MI-001 Water meters	MI-006 Automatic weighing instruments
MI-002 Gas meters	MI-007 Taximeters
MI-003 Active electrical energy meters and measurement transformers	[MI-008 Material measures, no software, not relevant here]
MI-004 Heat meters	MI-009 Dimensional measuring instruments
MI-005 Measuring systems for the continuous and dynamic measurement of quantities of liquids other than water	MI-010 Evidential breath analyzers
	MI-011 Exhaust gas analyzers

5.5 Technical features of measuring instruments and systems

When working out detailed software requirements for software controlled measuring instruments it is necessary to take into account not only the levels as defined above, but also certain technical features, i.e. possible hardware configurations and software features. These can be observed and classified objectively. WELMEC guide 7.1 proposes 25 “cases” for classifying measuring instruments and systems into 5 basic hardware configurations and 20 basic software features which are presented in 5.5.1 to 5.5.8.

5.5.1 Hardware configurations

The variability of the hardware of measuring systems is represented by five basic configuration models, cases (a) to (e). The modules or devices can be realized as built-for-purpose devices - normally cases (a) to (d) - or as non-built-for-purpose devices - normally case (e). The latter may be personal computers, workstations or even mainframes.

- (a) Stand-alone instrument subject to legal control, no hardware interface for connection of peripherals.

- (b) Instrument subject to legal control with the option of connecting a peripheral device not subject to legal control by a protective hardware interface.
- (c) Modular measuring system, all modules subject to legal control, protective or non-protective hardware interfaces, closed communication bus system (no connection to network).
- (d) Modular measuring system, some modules subject to legal control, protective hardware interfaces, closed communication bus system (no connection to network).
- (e) Modular measuring system, some modules subject to legal control, protective hardware interfaces, open communication bus system (connection to devices in a network).

5.5.2 User interface (shell)

The user interface (shell) consists of input media (e.g. keyboard, mouse) and output media (e.g. display, video monitor or printer).

- (f) User shell always in operating mode subject to legal control.
- (g) User shell can be switched from operating mode subject to control to operating mode not subject to control and vice versa. The user may, for instance, stop the measuring program, start a text processor and then start the measuring program again.

- (h) Free user shell with operating modes subject to control and operating modes not subject to control in parallel. There is, for instance, one window in a Windows operating system that represents the user interface subject to control.

5.5.3 Software loading

- (i) No loading possible, programs are invariable (firmware, usually stored in a non-volatile memory, e.g. in a non-detachable, soldered EPROM).
- (j) The manufacturer fixes all of the programs subject to control and all of those not subject to control that are loadable. Loading can be realized by changeable storage (CD-ROM, etc.) or by downloading via interface from a server (to hard disc drive, Flash ROM, EEPROM etc).
- (k) Any program can be loaded. Loading can be realized by changeable storages (floppy disc, CD-ROM, etc.) or by downloading via interface from a server (to hard disc drive, Flash ROM, EEPROM, etc.).

5.5.4 Software structure

- (l) The software is subject to legal control as a whole and is not intended to be modified after approval.
- (m) Parts of the software are subject to legal control. Other parts that are not legally relevant are intended to be modified after approval.

5.5.5 Software environment

- (o) The software environment is invariable. The whole of the instrument's software has been constructed for the measuring purpose.
- (p) The software subject to control is embedded in an environment like a standard operating system that is not especially constructed for the measuring purpose.

5.5.6 Fault detection

- (q) The presence of a defect is obvious or can simply be checked or there are hardware means for fault detection.
- (r) The presence of a defect is not obvious and cannot be easily and simply checked using devices apart from the instrument itself and there are no hardware means for fault detection.

5.5.7 Long-term storage of measurement values

- (s) No long-term data storage of measurement values in the system.
- (t) Measurement values are stored in the system for later legal use.

5.5.8 Measuring principle

Time dependence:

- (u) Cumulative measurement (e.g. counter, fuel dispenser).
- (v) Single independent measurement.

Repeatability:

- (w) Repeatable measurement.
- (x) Non-repeatable measurement.

Complexity:

- (y) Simple, straightforward, or static measurement.
- (z) Complex or dynamic measurement.

5.6 Examples for interpretation of the essential software requirements

WELMEC guide 7.1 contains two examples to illustrate how a set of detailed, specific software requirements can be derived from the essential software requirements taking into account the levels chosen and the technical features assigned by the manufacturer.

5.6.1 Example A:

Simple stand-alone measuring instrument

This is a simple stand-alone measuring instrument, realized as built-for-purpose device with all components inside one housing (see Fig. 2). In principle this example stands for a broad variety of instruments used for commercial transactions such as fueling points, retail scales and taximeters.

Here it is assumed that the instrument is characterized by the following general technical features:

- Closed housing. All components of the instrument are within the housing; sealing possible.

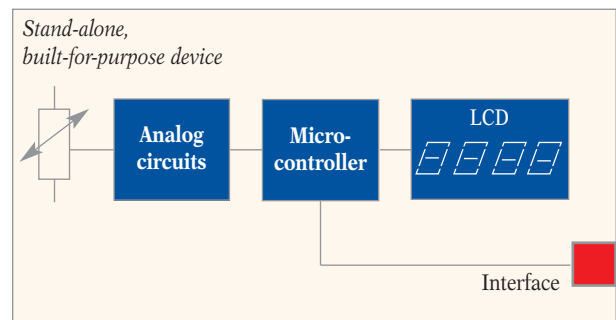

Fig. 2 Example A: Simple stand-alone measuring instrument

- The instrument consists of a sensor (transducer, including analogue electronics), further analog components (e.g. A/D converter), a microprocessor board and an LC display.
- The device has a hardware interface that is intended for connecting a peripheral device not subject to legal control.
- The software is stored in a non-volatile memory (non-detachable Flash ROM, EEPROM, EPROM or PROM).
- The entire software is not intended to be changed after type approval. There is no software separation of legally relevant program parts and other parts realized.
- Fault detection: checksum calculation over the memory contents.

According to 5.5, this leads to the following classification:

- Hardware configuration: case (b)
- User interface (shell): case (f)
- Software loading: case (i)
- Software structure: case (l)
- Software environment: case (o)
- Fault detection: case (r)
- Long-term storage of measurement values: case (s)
- Measuring principle: cases (v, w, y)

One example of a detailed software requirement for the subject “Software protection of legally relevant program parts and data” and for the chosen software protection level “high” is:

“Either the housing of the instrument has to be secured, or the program and data memory must be secured against unauthorized removal.”

Complete sets of detailed, specific software requirements for each level can be found in WELMEC 7.1.

5.6.2 Example B: Computer-based, modular, complex measuring system

This is a typical computer-based multifunctional device used in an open network (see Fig. 3). Such measuring systems can, for instance, be found in applications such as automatic rail-weighbridges, dimensional measuring instruments often in combination with weighing systems or point-of-sale (POS) devices.

The technical features and the respective classification of this example can be found in WELMEC 7.1.

An example of a detailed software requirement for the subject “Software protection of transmitted data” and for the chosen software protection level “middle” is:

“The legally relevant transmitted data must be protected against intentional changes with simple common software tools (text editors). This can be realized e.g. by an electronic signature or by encryption. The security level depends on the algorithm and key length of the signature (or encryption). An acceptable solution for the protection level middle would be e.g. the CRC algorithm with a key/signature length of 2 bytes for each data set with one measurement value.”

Complete sets of detailed, specific software requirements for each level can be found in WELMEC 7.1.

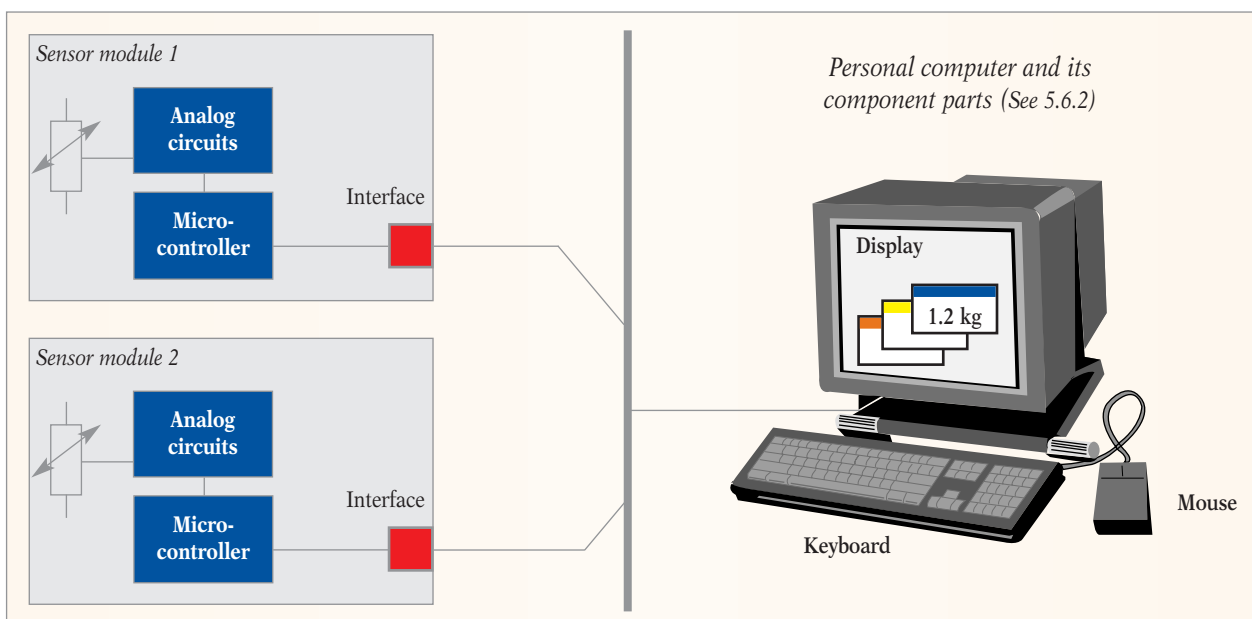

Fig. 3 Example B: Computer-based, modular, complex measuring system

6 Summary and outlook

- Software is an issue of rapidly growing importance, also in legal metrology. Legal metrologists should find an appropriate answer by defining adequate and clear software requirements and conducting competent software examination.
- WELMEC Guide 2.3 for weighing instruments was a first step to harmonizing software examination in Europe by fixing the levels for the strength of *protection of software* against corruption, the intensity of *examination of software* at type approval, and the *degree of conformity* between the software implemented in a verified instrument and the approved software.
- Based on the experiences with WELMEC 2.3, the general WELMEC Software Guide 7.1 has been completed by WELMEC WG7 in 1999. After approval by the WELMEC Committee it has recently been published. It is also available on the WELMEC web site www.welmec.org/publications.
- The WELMEC Software Guide 7.1 is a general guideline which will serve as the basis for future work in WG7. It is intended to demonstrate the approximate direction and important aspects of software examination rather than to detail specific software requirements for each kind of measuring instrument. It will, therefore, be successively amended by specific annexes or supplementary guidelines that will contain software requirements, checklists, examples of acceptable technical solutions and other recommendations for the measuring instruments covered by the MID.
- WELMEC supports the issue of software to be taken up by the OIML. At the 34th CIML Meeting (October 1999), it was decided to establish a new OIML Subcommittee SC 2 "Software in legal metrology" under the Technical Committee TC 5 "Electronic instruments and software", the responsibility for the new TC 5/SC 2 being with France and Germany [8]. ■

7 References

- [1] Document WELMEC 1, An Introduction to WELMEC, WELMEC Secretariat, Teddington, Issue 4, 1999
- [2] Council Directive 90/384/EEC on the harmonization of the laws of the Member States relating to non-automatic weighing instruments. Official Journal of the European Communities, L 189, Vol. 33, 20.7.1990, 1-16
- [3] Document WELMEC 2.3, Guide for Examining Software (Non-automatic Weighing Instruments), Issue 1, 1995, and WELMEC 2.3 (Amendment), 1997
- [4] International Recommendation OIML R 76-1: Nonautomatic weighing instruments, Part 1: Metrological and technical requirements - Tests. OIML, Paris, 1992
- [5] Measuring Instruments Directive (MID/3), 1998, Working Document, European Commission - III.D.2
- [6] Document WELMEC Guide 7.1, Software Requirements on the Basis of the Measuring Instruments Directive (MID), WELMEC Secretariat, Teddington, Issue 1, 1999
- [7] Security of computerized instruments, Jean-François Magana, OIML Bulletin, Vol. XL, No. 3, July 1999, 16-23
- [8] 34th Meeting of the International Committee of Legal Metrology, 6-8 October 1999, OIML Bulletin, Vol. XLI, No. 1, January 2000, 27-32



Dr. Roman Schwartz

Head of Weighing
Instruments Laboratory,
PTB, Braunschweig, Germany

E-mail: roman.schwartz@ptb.de



Dr. Ulrich Grottker

Project Leader, "Software
Examination in Legal Metrology",
PTB, Braunschweig, Germany

E-mail: ulrich.grottker@ptb.de



100 YEARS OF THE VNIIMS

Main Russian State Metrology Service Scientific Center commemorates centenary

ALEXANDR ASTASHENKOV, Director of VNIIMS (Gosstandart of Russia), Moscow

Metrology as a science and as a measurement-related activity only emerged in the majority of states in the middle of the 19th to the beginning of the 20th centuries.

In Russia, 1842 was marked by the adoption of an “Act on Weights and Measures” and by the establishment of a *Dépôt* of standard measures. In 1893 the *Dépôt* was reorganized as the Main Chamber of Weights and Measures, which is at present the D.I. Mendeleev Institute of Metrology - the VNIIM.

The D.I. Mendeleev measurement affairs reform gave rise to the establishment of local verification offices: the first two were set up in St. Petersburg, then one in Moscow, another in Warsaw, and one railway coach verification unit was created.

In 1875 Russia signed the Meter Convention and the First CGPM was held; then in 1895 a correlation was established between the Russian, Metric and British systems of measurements.

The inauguration of the Moscow Verification Office on 1 October 1900 is actually the “birthday” of the VNIIMS, the Russian research institute of metrological service, which was equipped with metric standard measures. In 1900–1901 the Office verified 99.9 % and in 1902 99.7 % of the total measures to be checked within the verification system.

The Moscow Office played an important role in introducing the metric system in Russia and in 1923 the system was admitted at national level. The same Office was also involved in verifying instruments manufactured abroad that were imported into Russia in great number. For example in 1925–1926, 18 240 scales, 499 074 length measures and 466 505 imported thermometers were verified. These represented 99.9 %, 77.8 % and 67.1 % respectively of the total instruments verified, since the majority of imported measures and instruments had to pass quality inspection in Moscow due to the State monopoly on foreign trade.

In 1927 the Moscow Verification Office was reorganized into the Weights and Measures Chamber of the

Russian Soviet Federal Socialist Republic (RSFSR), and until 1932 it was not only entrusted with verification, but also with the supervision of verification laboratories in the RSFSR.

In 1933 on the basis of the Chamber’s laboratories, the Institute for Metrology and Standardization was established, which in 1934 was reorganized into the Russian Research Institute of Metrology. In that year, the Institute conducted its first type evaluation (a domestic-produced dynamometer), and the State Register of type approved instruments was launched.

By 1940 the Institute had already tested 66 types of instruments, developed 14 verification instructions, conducted 15 research themes, and verified a great number of instruments. At that time the Institute had 500 staff members. During wartime 1941–1945, some specialists and equipment were evacuated to Tomsk, Barnaul and other cities in order to provide assistance to enterprises that had also been evacuated there.

In 1947 a Central Research Bureau of Uniform Time Service was created at the Institute, which was reorganized in 1953 as a separate Institute of Radio Technical Measurements (at present - VNIIFTRI).

It may be of interest to note that scientific staff growth was as follows:

1949: 14 doctors and candidates of science (PhD) out of 78 research workers;

1957: 26 doctors and candidates out of 171 researchers;

2000: 64 doctors and candidates out of 272 researchers and engineers.

The Government and the Party’s decree issued in December 1972 established a new organization of the State Metrological Service, and the Institute was assigned the function of Head Center of the State Metrological Service; it was reorganized into the All-Union Research Institute of Metrological Service - VNIIMS.

In 1974 a group of scientists from academic institutes joined the VNIIMS, making it possible to expand a program of fundamental research in such directions as investigation of new principles for creating measure-

ment standards and high precision measuring instruments in quantum metrology, determination of molecular constants, problems in gas discharge, superconductivity, electron processes, and gravitation. Simultaneously, much work was conducted on guidance of type evaluation and approval of measuring instruments, development of a normative base of legal metrology, and methodological guidance of the State and departmental metrological organizations. This work was aimed at ensuring measurement uniformity in the country, and providing State supervision and departmental control over the condition and application of measuring instruments.

In 1974 the State Service of Standard Reference Data on Physical Constants and Properties of Substances and Materials (GSSSD) was attached to the VNIIMS.

In 1975 when the VNIIMS commemorated its 75th anniversary, the Institute's staff totaled 800. In the same year, the interdepartmental Scientific Council on Measurement Problems was organized as proposed by the USSR Academy of Sciences, the Ministry of Higher Education, the Gosstandart and the Ministry of Defense. At that time, the first All-Union scientific and technological conference "Metrological assurance of the national economy" was organized and held by the VNIIMS; such conferences became a tradition. The most recent one, convened as before by the VNIIMS, took place in Yaroslavl in 1999.

In April 1993 the Russian Parliament adopted the Law on "Assurance of measurement uniformity", developed by VNIIMS specialists. The Institute made good progress in the work of putting the Law's principles into metrological practice.

Today, the VNIIMS is accredited not only as a scientific organization, but also as the State center for testing, certification and verification of measuring instruments, as well as a scientific and methodological center for the Russian calibration system, etc. (see Fig. 1). The VNIIMS consists of two main parts: a group of divisions which ensure the function of the Head Center of the State Metrological Service and a group of laboratories that perform the function of a center for measurement standards in assigned measurement classes and fields (see Fig. 2).

Together with the other metrological institutes of the Gosstandart of Russia, the VNIIMS continues work aimed at improving the State system for ensuring the uniformity of measurements (GSI). This is a guiding system that includes legal, organizational and technical subsystems.

The VNIIMS is the State scientific metrology center (GNMC) which includes (besides itself) the Scientific Center for Surface and Vacuum Research (NICPV) and the Russian Research Center for Standardization, Information and Certification of Raw Materials, Substances and Materials (VNICSMV).

One of the important priorities of the VNIIMS is its active participation in the diversity of accreditation, which ensures mutual confidence between consumers and producers of metrological work and services, confirmation of technical competence and independence of the latter, creation of the necessary conditions for international recognition of measurement and test results and their certificates. Since 1993 and to date, hundreds of metrology services, test and measurement laboratories and centers have been accredited for technical competence, verification rights, calibration etc.

The international activity of the VNIIMS is connected with scientific and methodological guidance and coordination of international work in the field of metrology within the country; the Institute is responsible for a number of Russia's secretariats for the OIML, ISO, COOMET, APLMF, CIS, etc. The VNIIMS is a participant of the Mutual Recognition Arrangement of national measurement standards and of calibration and measurement certificates issued by national metrology institutes which was signed in Paris on 14 October 1999 during the 21st CGPM. The Institute also actively cooperates with the PTB, NPL, NIST, BIPM and other organizations.

Comprising today over 20 divisions and laboratories, the VNIIMS is a base Institute for the country's legal metrology activities and is a reliable partner in international cooperation, such as will be demonstrated once again during the Jubilee Conference in Moscow on 2-3 October 2000, devoted to the 100th anniversary of the VNIIMS. ■

Contact information:

Dr. Alexandr Astashenkov

Director of Russian Research Institute for Metrological Service
(VNIIMS) of the Gosstandart of Russia

46 Ozernaya ul., G-361, Moscow 119361, Russia

Tel: (095) 437 55 77

Fax: (095) 437 56 66

Email: Office.VNIIMS@g.23.relcom.ru

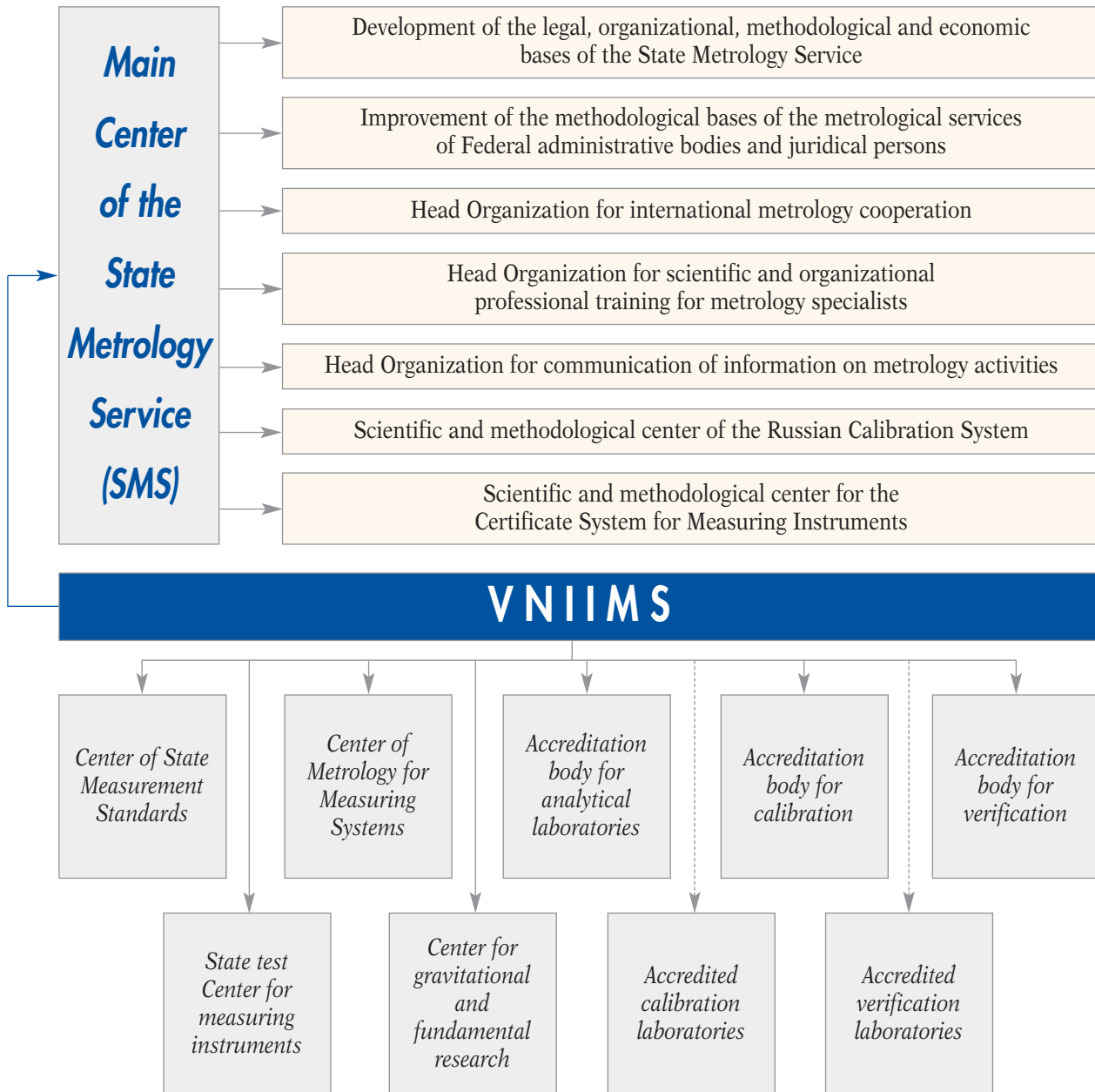

Fig. 1 Basic functions of the VNIIMS

<p>Entrusted measurement fields:</p> <ul style="list-style-type: none"> • Pressure measurement • Geometric parameters of surface finish • High and super-high voltage • Composition and properties of substances by means of chromatographic and optical methods • Linear and angular vibration and variable forces 	<p>VNIIMS as a center of measurement standards:</p> <ul style="list-style-type: none"> • Ensures maintenance and functioning of State and working standards and instruments of the highest accuracy • Carries out their research and improvement • Performs fundamental and applied investigations aimed at developing new generations of standards
---	---

Fig. 2 VNIIMS - Center of measurement standards



TUNISIE – TUNISIA

Note d'information sur la loi tunisienne relative à la métrologie légale

Information on the Tunisian Law relating to legal metrology

GHAÏET-EL-MOUNA ANNABI, Directeur de la Qualité et de la Protection du Consommateur, Ministère du Commerce, Tunis

Promulgation de la loi n° 99-40 du 10 mai 1999 relative à la métrologie légale, entrée en vigueur le 14 novembre 1999

Promulgation of Law no. 99-40 dated 10 May 1999 relating to legal metrology, enacted on 14 November 1999

L'esprit de cette loi s'inspire des normes et publications internationales, en l'occurrence les Documents et Recommandations de l'OIML, et tient compte des orientations économiques de la Tunisie tournées vers la libéralisation des produits et services, et la déréglementation.

Cette loi propose ainsi des réformes quant aux structures fonctionnelles et organisationnelles du service chargé de la métrologie légale, et se caractérise par une meilleure définition des contrôles métrologiques légaux et des instruments et méthodes de mesure soumis à des exigences réglementées.

Les principaux éléments de cette réforme sont:

- 1) La définition des unités de mesure légales: Unités du Système International (SI), et autres unités spécifiques à la Tunisie et habituellement utilisées dans des usages bien déterminés.
- 2) L'identification des contrôles métrologiques légaux: Approbation de modèle, vérification primitive, vérification périodique, contrôle technique, surveillance métrologique, contrôle des préemballés.
- 3) L'identification des instruments de mesure réglementés: Instruments utilisés dans les domaines du commerce, de la santé, de la sécurité, de l'environnement, et des contrôles officiels.
- 4) La responsabilisation d'organismes habilités: Laboratoires et entreprises, publiques ou privées, ayant les compétences, le savoir-faire, et les équipements adéquats pour l'exercice d'une activité de métrologie légale.
- 5) L'institution d'un Conseil National de Métrologie Légale: Institution à caractère consultatif, et regroupant des représentants de différents départements ministériels concernés par les activités de mesurage ou des activités connexes (enseignement de la métrologie, formation, etc.). ■

The essence of this Law is inspired from international standards and publications, specifically OIML Documents and Recommendations, and takes into account Tunisian economic orientations which center on liberalization of products and services and deregulation.

This Law thus provides for both functional and organizational structural reforms of the legal metrology service, and is characterized by a better definition of legal metrology controls and of measuring instruments and methods subject to regulated requirements.

The principal elements of this reform are:

- 1) The definition of legal measurement units: International System (SI) Units, and other units specific to Tunisia that are generally used in very precise cases.
- 2) The identification of legal metrological controls: Pattern approval, initial verification, periodic verification, technical checks, metrological supervision and prepackage control.
- 3) The identification of regulated measuring instruments: Instruments used in the fields of commerce, health, safety, the environment and official controls.
- 4) The sense of responsibility of authorized bodies: Laboratories and enterprises (public or private) that have the skill, know-how and appropriate equipment to exercise a legal metrology activity.
- 5) The institution of a National Legal Metrology Council: Institution of a consultative nature, grouping together representatives of the various ministerial departments that are concerned by measurement or measurement-related activities (teaching of metrology, training, etc.). ■



REVISION OF OIML D 11 (1994)

Status of revision, and comments on changes in the numbering of IEC Publications

GEP ENGLER, OIML Contact Person, NMI (Netherlands) - OIML TC 5/SC 1 Secretary

OIML International Document D 11 (1994) *General requirements for electronic measuring instruments* is an important guide for all those who draft OIML Recommendations for electronic instruments or measuring instruments with electronic devices, and facilitates appropriate referencing to international standards, in particular IEC Publications.

As many readers of the OIML Bulletin will know, D 11 is currently under revision and the Dutch National Working Group (OIML TC 5/SC 1 Secretariat) is preparing revision proposals.

The NWG convened on 17 January, 11 February, 6 March and 5 April 2000 to further discuss revisions to this Document. On 5 April the 5th draft revision was reviewed; besides some editorial changes, the most important proposals currently under preparation at this stage are:

- to bring D 11 into line with the current versions of IEC Publications, including the influence of hand-held wireless telephones;
- to introduce a test for power frequency magnetic field (50/60 Hz) according to IEC 61000-4-8;
- to make a clear distinction between equipment powered by “small” built-in batteries (non-rechargeable/rechargeable) and external (car etc.) batteries; and
- elaboration of the tests for equipment powered by batteries in cars etc., based on ISO 7637-0, -1, -2 and -3.

Since the publication of D 11, many IEC Publications have been revised and their numbering system has also been changed. This article lists the updated references to be utilized in the development and/or revision of OIML Documents and Recommendations.

As from 1997 all new IEC publications and parts, as well as new editions, revisions and amendments to existing publications, are being issued with a designation in the 60000 series. Therefore, “60000” has been added to all existing base numbers. The IEC databases

accessed via IEC’s web site (and the IEC catalogue in particular) take account of this renumbering, but users should be aware that older publications (i.e. printed before 1997) will continue to carry the old series of numbers on printed copies until they are revised, but that they are classified by their respective 60000 numbers both in bibliographic reference material and on invoices.

Besides these changes in the numbers, many IEC Publications have also been revised since the current version (1994) of D 11 was originally drafted. The table on the following pages gives an overview of the actual situation, compared to the “Notes and Bibliography” on pages 30–31 of D 11, sorted by Reference number [...]. For completeness, ISO 7637 has also been included.

Note: By the time this article is published, the proposals for revision will have been distributed to the P- and O-Members of OIML TC 5/SC 1, as well as to Liaison Organizations.



OIML D 11 (1994) is under revision. The tables on the following pages give the updated IEC Publication references

Ref. in D 11 (1994)	IEC Publication, as it appears in the present 1994 edition of D 11	Current IEC Publication	Short description of the contents of the current IEC Publication	Remarks and actual situation (April 2000)
[1]	IEC 68-1 (no year mentioned) Appendix B	IEC 60068-1 IEC 60068-1-am1 Environmental testing Part 1: General and guidance	Enumerates a series of environmental tests and appropriate severities, and prescribes various atmospheric conditions for measurements for the ability of specimens to perform under normal conditions of transportation, storage and operational use.	(*) (1)
[2]	IEC 721-3-3 (1987) Classification of groups of environmental parameters and their severities - Stationary use at weatherprotected locations	IEC 60721-3-3 IEC 60721-3-3-am1 IEC 60721-3-3-am2 Classification of environmental conditions Part 3: Classification of groups of environmental parameters and their severities Section 3: Stationary use at weatherprotected locations	Classifies groups of environmental parameters and their severities to which products are subjected when mounted for stationary use at weatherprotected locations.	(1)
[2]	IEC 721-3-4 (1987) Classification of groups of environmental parameters and their severities - Stationary use at non-weatherprotected locations	IEC 60721-3-4 IEC 60721-3-4-am1 Classification of environmental conditions Part 3: Classification of groups of environmental parameters and their severities Section 4: Stationary use at non-weatherprotected locations	Classifies groups of environmental parameters and the severities to which a product may be exposed under use conditions, including periods of erection work, downtime, maintenance and repair, when mounted for stationary use at locations that are non-weatherprotected.	(1)
[3]	IEC Committee Draft 77 (Secretariat) 118 Classification of electromagnetic environments	IEC 61000-2-5 Basic EMC publication Electromagnetic compatibility (EMC) Part 2: Environment Section 5: Classification of electromagnetic environments	This publication is a technical report intended for guidance, not as a specification, for those who are in charge of writing immunity standards for an equipment or system. Its purpose is to classify electromagnetic environments and help improve the specification of the immunity requirements of an item containing electrical or electronic parts, and consequently obtain electromagnetic compatibility. It also gives basic guidance for the selection of immunity levels. The data are applicable to any equipment, subsystem or system making use of electromagnetic energy and operating in a specific location as defined by this report.	(1)

(*) Only the number has been changed (1) Situation in April 2000: No work in progress (2) Situation in April 2000: Work in progress. For details refer to <http://www.iec.ch>
This list is based on the index of IEC Publications on the Internet (as published in April 2000): <http://www.iec.ch>

<i>Ref. in D 11 (1994)</i>	<i>IEC Publication, as it appears in the present 1994 edition of D 11</i>	<i>Current IEC Publication</i>	<i>Short description of the contents of the current IEC Publication</i>	<i>Remarks and actual situation (April 2000)</i>
[4]	IEC 68-2-2 (1974) Basic environmental testing procedures, Part 2: Tests, Test Bd: Dry heat for heat-dissipating specimen with gradual change of temperature	IEC 60068-2-2 (1974-01) IEC 60068-2-2-am1 (1993-02) IEC 60068-2-2-am2 (1994-05) Environmental testing Part 2: Tests, Test B: Dry heat	Contains Test Ba: Dry heat for non-heat-dissipating specimen with sudden change of temperature; Test Bb: Dry heat for non-heat-dissipating specimen with gradual change of temperature; Test Bc: Dry heat for heat-dissipating specimen with sudden change of temperature; Test Bd: Dry heat for heat-dissipating specimen with gradual change of temperature. The 1987 reprint includes IEC No. 62-2-2A.	(*) (1)
[4], [5]	IEC 68-3-1 (1974) + Supplement (1978) Background information, Section 1: Cold and dry heat tests	IEC 60068-3-1 (1974-01) IEC 60068-3-1A (1978-01) Environmental testing Part 3: Background information Section 1: Cold and dry heat tests	Gives background information for Tests A: Cold (IEC 68-2-1), and Tests B: Dry heat (IEC 68-2-2). Includes appendices on the effect of: chamber size on the surface temperature of a specimen when no forced air circulation is used; airflow on chamber conditions and on surface temperatures of test specimens; wire termination dimensions and material on surface temperature of a component; measurements of temperature, air velocity and emission coefficient. Supplement A gives additional information for cases where temperature stability is not achieved during the test.	(*) (*) (1)
[5]	IEC 68-2-1 (1974) + Supplement A (1976) Basic environmental testing procedures, Part 2: Tests, Test Ad: Cold for heat-dissipating specimen with gradual change of temperature	IEC 60068-2-1 (1990-05) IEC 60068-2-1-am1 (1993-02) IEC 60068-2-1-am2 (1994-06) Environmental testing Part 2: Tests Test A: Cold	Concerns cold tests on both non-heat-dissipating and heat-dissipating specimens.	(2)
[6]	IEC 68-2-3 (1969) Basic environmental testing procedures, Part 2: Tests - Test Ca: Damp heat, steady state	IEC 60068-2-3 (1969-01) Environmental testing Part 2: Tests Test Ca: Damp heat, steady state	Describes a continuous test at a steady temperature of 40 °C and a relative humidity of 90–95 %. The standard test duration is 4 to 56 days.	(*) (1)
[6]	IEC 68-2-56 (1988) Test Cb Environmental testing - Part 2: Tests, Test Cb: Damp heat, steady state, primarily for equipment	IEC 60068-2-56 (1988-12) Environmental testing Part 2: Tests Test Cb: Damp heat, steady state, primarily for equipment	Determines the suitability of electrotechnical products, principally equipment, for use and storage under conditions of high humidity.	(*) (1)
[6], [7]	IEC 68-2-28 (1980) Guidance for damp heat tests	IEC 60068-2-28 (1990-03) Environmental testing Part 2: Tests, Guidance for damp heat tests	Determines the ability of electrotechnical products to withstand the stresses occurring in a climate of high relative humidity, with or without condensation, with special regard to electrical and mechanical characteristics.	(1)

(*) Only the number has been changed (1) Situation in April 2000: No work in progress (2) Situation in April 2000: Work in progress. For details refer to <http://www.iec.ch>
This list is based on the index of IEC Publications on the Internet (as published in April 2000): <http://www.iec.ch>

Ref. in D 11 (1994)	IEC Publication, as it appears in the present 1994 edition of D 11	Current IEC Publication	Short description of the contents of the current IEC Publication	Remarks and actual situation (April 2000)
[7]	IEC 68-2-30 (1980) Basic environmental testing procedures, Part 2: Tests, Test Db and guidance: Damp heat, cyclic (12 + 12 hour cycle), test variant 1	IEC 60068-2-30 IEC 60068-2-30-am1 Environmental testing Part 2: Tests Test Db and guidance: Damp heat, cyclic (12 + 12-hour cycle) Amendment No. 1 replaces the third paragraph of Clause 8, Recovery	Determines the suitability of components, equipment and other articles for use and/or storage under conditions of high humidity when combined with cyclic temperature changes.	(*) (1)
[8]	IEC 68-2-34 (1973) Test Fd: Random vibration wide band - General requirements Withdrawn in 1999	Replaced by: IEC 60068-2-64 (1993) IEC 60068-2-64 Corr.1 (1993-10) Environmental testing Part 2: Test methods Test Fh: Vibration, broad-band random (digital control) and guidance	Determines the ability to withstand specified severities of broad-band random vibration. Applies to specimens which may be subjected to vibration of a stochastic nature by transportation or operational environments, for example in aircraft, space vehicles and land vehicles. Has the status of a basic safety publication in accordance with IEC Guide 104.	(1)
[8]	IEC 68-2-36 (1973) + Amendment 1 (1983) Basic environmental testing procedures, Part 2: Tests, Test Fdb: Random vibration wide band - Reproducibility Medium Withdrawn in 1999			
[9]	IEC 68-2-6 (1982) + Amendments 1 and 2 (1985) Basic environmental testing procedures, Part 2: Tests, Test Fc and guidance: Vibration (sinusoidal)	IEC 60068-2-6 (1995-03) IEC 60068-2-6 corr.1 (1995-03) Environmental testing - Part 2: Tests - Test Fc: Vibration (sinusoidal)	Gives a method of test which provides a standard procedure to determine the ability of components, equipment and other articles to withstand specified severities of sinusoidal vibration. Has the status of a basic safety publication in accordance with IEC Guide 104.	(1)
[9]	IEC 68-2-47 Environmental testing - Part 2-47: Test methods - Mounting of components, equipment and other articles for vibration, impact and similar dynamic tests	IEC 60068-2-47 (1999-10) Environmental testing Part 2-47: Test methods Mounting of components, equipment and other articles for vibration, impact and similar dynamic tests	Provides methods of mounting components, and mounting requirements for equipment and other articles, for the families of dynamic tests in IEC 60068-2, that is impact (Test E), vibration (Test F) and acceleration, steady-state (Test G).	(1)
[10]	IEC 68-2-31 (1969) + Amendment 1 (1982) Basic environmental testing procedures, Part 2: Tests - Test Ec: Drop and topple, primarily for equipment-type specimens (Procedure 2.a: Dropping on to a face)	IEC 60068-2-31 (1969-01) IEC 60068-2-31-am1 (1982-01) Environmental testing Part 2: Tests Test Ec: Drop and topple, primarily for equipment-type specimens	Determines the effect on a specimen of simple standard treatments which are representative of the knocks and jolts likely to occur during repair work or rough handling on a table or bench. Has the status of a basic safety publication in accordance with IEC Guide 104.	(*) (*) (1)

(*) Only the number has been changed (1) Situation in April 2000: No work in progress (2) Situation in April 2000: Work in progress. For details refer to <http://www.iec.ch>
This list is based on the index of IEC Publications on the Internet (as published in April 2000): <http://www.iec.ch>

Ref. in D 11 (1994)	IEC Publication, as it appears in the present 1994 edition of D 11	Current IEC Publication	Short description of the contents of the current IEC Publication	Remarks and actual situation (April 2000)
[11]	IEC 1000-2-1 Electromagnetic compatibility (EMC) - Part 2: Environment - Section 1: Description of the environment - Electromagnetic environment for low-frequency conducted disturbances and signalling in public power supply systems	IEC/TR3 61000-2-1 (1990-05) Electromagnetic compatibility (EMC) Part 2: Environment Section 1: Description of the environment - Electromagnetic environment for low-frequency conducted disturbances and signalling in public power supply systems	Has the status of a technical report, and gives information on the various types of disturbances that can be expected on public power supply systems. The following disturbance phenomena are considered: harmonics - inter-harmonics - voltage fluctuations - voltage dips and short supply interruptions - voltage unbalance - mains signalling - power frequency variation - d.c. components.	(*) (1)
[11]	IEC 1000-2-2 Electromagnetic compatibility (EMC) - Part 2: Environment - Section 2: Compatibility levels for low-frequency conducted disturbances and signalling in public low-voltage power supply systems	IEC 61000-2-2 (1990-05) Electromagnetic compatibility (EMC) Part 2: Environment Section 2: Compatibility levels for low-frequency conducted disturbances and signalling in public low-voltage power supply systems	Gives compatibility levels to be considered in public low-voltage supply systems with regard to the above-mentioned phenomena. Compatibility levels are intended to serve as reference values for trouble-free operation for equipment installed in public power supply systems.	(*) (2)
[11]	IEC 1000-4-1 Electromagnetic Compatibility (EMC) - Testing and measurement techniques - Overview of immunity tests	IEC 61000-4-1 (1992-12) Basic EMC Publication Electromagnetic compatibility (EMC) Part 4: Testing and measurement techniques Section 1: Overview of immunity tests.	Considers immunity tests for electric and/or electronic equipment (apparatus and systems) in its electromagnetic environment. Both conducted and radiated phenomena are considered including immunity tests for equipment connected to power, control and communication networks. Replaces IEC 60801-1 (1984-11).	(*) (2)
[12]	IEC 654-2 (1979) Operating conditions for industrial-process measurement and control equipment (under revision)	IEC 60654-2 (1979-01) IEC 60654-2-am1 (1992-09) Operating conditions for industrial-process measurement and control equipment Part 2: Power	Gives the limiting values for power received by land-based and offshore industrial-process measurement and control systems or parts of systems during operation. Maintenance and repair conditions are not considered.	(*) (1)
[13]	IEC 801-4 (1988) Electromagnetic compatibility for industrial-process measurement and control equipment, Part 4: Electrical fast transient/burst requirements (Work in progress: Amd. 1 and 2) Withdrawn in 1995	Replaced by IEC 61000-4-4 (1995-01) Electromagnetic compatibility (EMC) - Part 4: Testing and measurement techniques - Section 4: Electrical fast transient/burst immunity test. Basic EMC Publication	Relates to the immunity requirements and test methods for electrical and electronic equipment to repetitive electrical fast transients. Additionally defines ranges of test levels and establishes test procedures. The object of this standard is to establish a common and reproducible basis for evaluating the performance of electrical and electronic equipment when subjected to repetitive fast transients (bursts), on supply, signal and control ports. The test is intended to demonstrate the immunity of electrical and electronic equipment when subjected to types of transient disturbances such as those originating from switching transients (interruption of inductive loads, relay contact bounce, etc.). The standard defines test voltage waveform, range of test levels, test equipment, test set-up and test procedure.	(2)

(*) Only the number has been changed (1) Situation in April 2000: No work in progress (2) Situation in April 2000: Work in progress. For details refer to <http://www.iec.ch>
This list is based on the index of IEC Publications on the Internet (as published in April 2000): <http://www.iec.ch>

Ref. in D 11 (1994)	IEC Publication, as it appears in the present 1994 edition of D 11	Current IEC Publication	Short description of the contents of the current IEC Publication	Remarks and actual situation (April 2000)
[14]	IEC 801-2 (1991) Electromagnetic compatibility for industrial-process measurement and control equipment, Part 2: Electrostatic discharge requirements Withdrawn in 1997	Replaced by IEC 61000-4-2 IEC 61000-4-2 -am1 Basic EMC Publication Electromagnetic compatibility (EMC) Part 4: Testing and measurement techniques Section 2: Electrostatic discharge immunity test	This publication is based on IEC 60801-2 (second edition: 1991). It relates to the immunity requirements and test methods for electrical and electronic equipment subjected to static electricity discharges, from operators directly, and to adjacent objects. It additionally defines ranges of test levels which relate to different environmental and installation conditions and establishes test procedures. The object of this standard is to establish a common and reproducible basis for evaluating the performance of electrical and electronic equipment when subjected to electrostatic discharges. In addition, it includes electrostatic discharges which may occur from personnel to objects near vital equipment.	Consolidated edition: IEC 61000-4-2 Ed.1.1 (1999-05) (2)
[15]	IEC 801-3 (1984) Electromagnetic compatibility for industrial-process measurement and control equipment, Part 3: Radiated electromagnetic field requirements (Work in progress: Amd. 2) Withdrawn in 1995	Revision published as IEC 61000-4-3 IEC 61000-4-3-am1 Electromagnetic compatibility (EMC) Part 4: Testing and measurement techniques Section 3: Radiated, radio-frequency, electromagnetic field immunity test	Applies to the immunity of electrical and electronic equipment to radiated electromagnetic energy. Establishes test levels and the required test procedures. Establishes a common reference for evaluating the performance of electrical and electronic equipment when subjected to radio-frequency electromagnetic fields.	Consolidated edition: IEC 61000-4-3 Ed.1.1 (1998-11) (2)
[16]	Intended IEC Publication 801-6 Electromagnetic compatibility for electrical and electronic equipment, Part 6: Immunity to conducted disturbances induced by radio frequency fields above 9 kHz. Not published	Present standard IEC 61000-4-6 IEC 61000-4-6 Corr.1 Electromagnetic compatibility (EMC) Part 4: Testing and measurement techniques Section 6: Immunity to conducted disturbances, induced by radio- frequency fields	Relates to the conducted immunity requirements of electrical and electronic equipment to electromagnetic disturbances coming from intended radio-frequency (RF) transmitters in the frequency range 9 kHz up to 80 MHz. Equipment not having at least one conducting cable (such as mains supply, signal line or earth connection), which can couple the equipment to the disturbing RF fields is excluded. This standard does not intend to specify the tests to be applied to particular apparatus or systems. Its main aim is to give a general basic reference to all concerned product committees of the IEC. The product committees (or users and manufacturers of equipment) remain responsible for the appropriate choice of the test and the severity level to be applied to their equipment.	(2)

(*) Only the number has been changed (1) Situation in April 2000: No work in progress (2) Situation in April 2000: Work in progress. For details refer to <http://www.iec.ch>
This list is based on the index of IEC Publications on the Internet (as published in April 2000): <http://www.iec.ch>

<i>Ref. in D 11 (1994)</i>	<i>ISO Publication, as it appears in the present 1994 edition of D 11</i>	<i>ISO Publication, including full title</i>	<i>Short description of the contents of the ISO Publication</i>	<i>Remarks and actual situation (April 2000)</i>
Clauses A.5 B.6.3	ISO 7637-0 (1990) ISO 7637-1 (1990) ISO 7637-2 (1990) Road vehicles - electrical disturbance by conducting and coupling	ISO 7637-0 (1990) Road vehicles - electrical disturbance by conducting and coupling Part 0: Definitions and general	Defines basic terms used in the various parts for electrical disturbance by conduction and coupling. Gives also general information relating to the whole International Standard and common to all parts.	In revision: ISO/CD 7637-1
	ISO 7637-1 (1990) Road vehicles - electrical disturbance by conducting and coupling. Part 1: Passenger cars and light commercial vehicles with nominal 12 V supply voltage - Electrical transient conduction along supply lines only	ISO 7637-1 (1990) Road vehicles - electrical disturbance by conducting and coupling. Part 1: Passenger cars and light commercial vehicles with nominal 12 V supply voltage - Electrical transient conduction along supply lines only	Specifies test methods and procedures to ensure the compatibility to conducted electrical transients of equipment installed on passenger cars and light commercial vehicles fitted with a 12 V electrical system. It describes bench tests for both the injection and measurement of transients.	In revision: Combined in ISO/CD 7637-2
	ISO 7637-2 (1990) Road vehicles - electrical disturbance by conducting and coupling Part 2: Commercial vehicles with nominal 24 V supply voltage - Electrical transient conduction along supply lines only	ISO 7637-2 (1990) Road vehicles - electrical disturbance by conducting and coupling Part 2: Commercial vehicles with nominal 24 V supply voltage - Electrical transient conduction along supply lines only	Specifies test methods and procedures to ensure the compatibility to conducted electrical transients of equipment installed on commercial vehicles fitted with a 24 V electrical system. It describes bench tests for both the injection and measurement of transients.	



In this Bulletin: OIML certificates registered

Dans ce Bulletin: certificats OIML enregistrés

2000.02 – 2000.04

OIML Certificate System

The OIML Certificate System for Measuring Instruments was introduced in 1991 to facilitate administrative procedures and lower costs associated with the international trade of measuring instruments subject to legal requirements.

The System provides the possibility for a manufacturer to obtain an OIML certificate and a test report indicating that a given instrument pattern complies with the requirements of relevant OIML International Recommendations.

Certificates are delivered by OIML Member States that have established one or several Issuing Authorities responsible for processing applications by manufacturers wishing to have their instrument patterns certified.

OIML certificates are accepted by national metrology services on a voluntary basis, and as the climate for mutual confidence and recognition of test results develops between OIML Members, the OIML Certificate System serves to simplify the pattern approval process for manufacturers and metrology authorities by eliminating costly duplication of application and test procedures. ■

Système de Certificats OIML

Le Système de Certificats OIML pour les Instruments de Mesure a été introduit en 1991 afin de faciliter les procédures administratives et d'abaisser les coûts liés au commerce international des instruments de mesure soumis aux exigences légales.

Le Système permet à un constructeur d'obtenir un certificat OIML et un rapport d'essai indiquant qu'un modèle d'instrument satisfait aux exigences des Recommandations OIML applicables.

Les certificats sont délivrés par les États Membres de l'OIML, qui ont établi une ou plusieurs autorités de délivrance responsables du traitement des demandes présentées par des constructeurs souhaitant voir certifier leurs modèles d'instruments.

Les services nationaux de métrologie légale peuvent accepter les certificats sur une base volontaire; avec le développement entre Membres OIML d'un climat de confiance mutuelle et de reconnaissance des résultats d'essais, le Système simplifie les processus d'approbation de modèle pour les constructeurs et les autorités métrologiques par l'élimination des répétitions coûteuses dans les procédures de demande et d'essai. ■

This list is classified by Issuing Authority; updated information on these Authorities may be obtained from the BIML.

Cette liste est classée par Autorité de délivrance; les informations à jour relatives à ces Autorités sont disponibles auprès du BIML.

OIML Recommendation applicable within the System / Year of publication

Recommandation OIML applicable dans le cadre du Système / Année d'édition

Certified pattern(s)
Modèle(s) certifié(s)

Applicant
Demandeur

► Issuing Authority / Autorité de délivrance

Physikalisch-Technische Bundesanstalt (PTB), Germany

R61/1996 - NL - 00.01

Type MP ... (Class X(1))

Atoma GmbH, Traunreuter Straße 2-4, D-84478 Waldkraiburg, Germany

For each Member State, certificates are numbered in the order of their issue (renumbered annually).

Pour chaque État Membre, les certificats sont numérotés par ordre de délivrance (cette numérotation est annuelle).

Year of issue

Année de délivrance

The code (ISO) of the Member State in which the certificate was issued.

Le code (ISO) indicatif de l'État Membre ayant délivré le certificat.

For up to date information on OIML certificates:

Pour des informations à jour sur les certificats OIML:

www.oiml.org

INSTRUMENT CATEGORY
CATÉGORIE D'INSTRUMENT

Diaphragm gas meters
Compteurs de gaz à parois déformables

R 31 (1995)

- ▶ Issuing Authority / *Autorité de délivrance*
Netherlands Measurement Institute (NMI) Certin B.V.,
The Netherlands

R31/1995-NL-00.01

*Models GR25M-NL, GR25M-NR, GR25M-FL,
GR25M-TL, GR25M-TWL, GR25M-LL, GR25M-LR*

Ricoh Elemex Corporation, 3/Fl. Nagoya Center Bldg., 2-2-13,
Nishiki, Naka-ku, Nagoya-shi, Japan

INSTRUMENT CATEGORY
CATÉGORIE D'INSTRUMENT

Automatic catchweighing instruments
*Instruments de pesage trieurs-étiqueteurs
à fonctionnement automatique*

R 51 (1996)

- ▶ Issuing Authority / *Autorité de délivrance*
Physikalisch-Technische Bundesanstalt (PTB),
Germany

R51/1996-DE-99.05

L2-PTLs... (Class Y(a))

Mettler-Toledo (Albstadt) GmbH, Unter dem Malesfelsen 34,
D-72458 Albstadt, Germany

- ▶ Issuing Authority / *Autorité de délivrance*
Netherlands Measurement Institute (NMI) Certin B.V.,
The Netherlands

R51/1996-NL-00.01

Types EC ... and IW-B ... (Classes X(1) and Y(a))

Optima Control Systems GmbH, Steinbeisweg 20,
D-74523 Schwäbisch Hall, Germany

R51/1996-NL-00.04

*System 2000 Plus, System 2300, System 3000
and System 3300 (Class Y(a))*

DIBAL S.A., c/ Astintze Kalea, 24, Poligono Industrial Neinver,
48016 Derio (Bilbao-Vizcaya), Spain

INSTRUMENT CATEGORY
CATÉGORIE D'INSTRUMENT

Load cells
Cellules de pesée

R 60 (1991), Annex A (1993)

- ▶ Issuing Authority / *Autorité de délivrance*
Physikalisch-Technische Bundesanstalt (PTB),
Germany

R60/1991-DE-99.03

*Strain-gauge double bending beam load cell, type SLB..
(Classes C1 and C3)*

Flintec GmbH, Bahnhofstraße 52-54,
D-74909 Meckesheim, Germany

R60/1991-DE-99.04

*Strain-gauge double bending beam load cell, type SB4
(Classes C1 up to C4 and C4 MI 7,5)*

Flintec GmbH, Bahnhofstraße 52-54,
D-74909 Meckesheim, Germany

R60/1991-DE-99.06

*Strain-gauge compression load cell, type RC 3
(Classes C1 up to C5 and C4 MI 8)*

Flintec GmbH, Bahnhofstraße 52-54,
D-74909 Meckesheim, Germany

- ▶ Issuing Authority / *Autorité de délivrance*
National Weights and Measures Laboratory (NWML),
United Kingdom

R60/1991-GB-00.01

Strain Gauge Compression Load Cell Type T302 (Class C5)

GEC Avery Limited, Foundry Lane, Smethwick, Warley,
West Midlands B66 2LP, United Kingdom

R60/1991-GB-00.02

Digital Load Cell Model T303 (Class C6)

GEC Avery Limited, Foundry Lane, Smethwick, Warley,
West Midlands B66 2LP, United Kingdom

► Issuing Authority / *Autorité de délivrance*

Netherlands Measurement Institute (NMI) Certin B.V.,
The Netherlands

R60/1991-NL-00.01

IMV1 and IMV2 (Class C)

Epel Industrial S.A., Ctra. Sta. Cruz de Calafell, 35 km. 9, 400,
08830 Sant Boi de Llobregat, Barcelona, Spain

R60/1991-NL-00.02

TSSP (Class C)

Cardinal Scale Manufacturing Co., 203 East Daugherty St.,
Webb City, Missouri 64870, USA

R60/1991-NL-00.04

NW3510 (Class C)

Nova Weigh Ltd., Colemeadow Road, Redditch,
Worcestershire B98 9PB, United Kingdom

R60/1991-NL-00.05

1242 (Class C)

Tedea Huntleigh International Ltd., 2 Hazoran Street,
Netanya 42506, Israël

INSTRUMENT CATEGORY
CATÉGORIE D'INSTRUMENT

Automatic gravimetric filling instruments
Doseuses pondérales à fonctionnement automatique

R 61 (1996)

► Issuing Authority / *Autorité de délivrance*

Netherlands Measurement Institute (NMI) Certin B.V.,
The Netherlands

R61/1996-NL-98.07 Rev. 1

*CCW-M-****(*)-*/**_**, CCW-NZ-****(*)-*/**_**,
CCW-RZ-****-*/**_**-N, CCW-DZ-****-*/**_**-N
(Class X(1))*

Ishida Co., Ltd., 44, Sanno-cho, Shogoin, Sakayo-ku,
Kyoto 606, Japan

INSTRUMENT CATEGORY
CATÉGORIE D'INSTRUMENT

Metrological regulation for load cells
(applicable to analog and/or digital load cells)

*Réglementation métrologique des cellules de pesée
(applicable aux cellules de pesée à affichage
analogique et/ou numérique)*

R 60 (2000)

► Issuing Authority / *Autorité de délivrance*

Danish Agency for Development of Trade
and Industry, Division of Metrology, Denmark

R60/2000-DK-00.01

*Digital, capacitive gauge, beam load cell, type SD
(Class C6)*

Eilersen Electric A/S, Kokkedal Industripark 4,
DK-2100 Copenhagen Ø, Denmark

► Issuing Authority / *Autorité de délivrance*

Netherlands Measurement Institute (NMI) Certin B.V.,
The Netherlands

R60/2000-NL-00.03

MTX (Class C)

Mettler-Toledo Inc., 1150 Dearborn Drive, Worthington,
OH 43085-6712, U.S.A.

R60/2000-NL-00.06

1130 (Class C)

Tedea Huntleigh International Ltd., 2 Hazoran Street,
Netanya 42506, Israël

INSTRUMENT CATEGORY
CATÉGORIE D'INSTRUMENT

Nonautomatic weighing instruments
Instruments de pesage à fonctionnement non automatique

R 76-1 (1992), R 76-2 (1993)

- ▶ **Issuing Authority / Autorité de délivrance**
Danish Agency for Development of Trade and Industry, Division of Metrology, Denmark

R76/1992-DK-99.05

748P/L (Classes III and IIII)

Cardinal Scale Manufacturing Co., 203 East Daugherty St.,
Webb City, Missouri 64870, USA

R76/1992-DK-99.06

758 and 758S/C (Classes III and IIII)

Cardinal Scale Manufacturing Co., 203 East Daugherty St.,
Webb City, Missouri 64870, USA

R76/1992-DK-00.01 Rev. 1

*Family LD5200 / DJB / DWI / RDT52A/B
(Classes III and IIII)*

Leon Engineering S.A., 41, Arcadia Street,
P.O. Box 14118, 115 10 Athens, Greece

R76/1992-DK-00.02

*D500 / D500N / D500BC / D500F / D500PS
(Classes III and IIII)*

Leon Engineering S.A., 41, Arcadia Street,
P.O. Box 14118, 115 10 Athens, Greece

R76/1992-DK-00.03

D500 Model Athena (Classes III and IIII)

Leon Engineering S.A., 41, Arcadia Street,
P.O. Box 14118, 115 10 Athens, Greece

- ▶ **Issuing Authority / Autorité de délivrance**
Sous-direction de la Métrologie, France

R76/1992-FR-97.02 Rev. 3

*Balance électronique TESTUT modèle B300
versions B300S et B317 (Classe III)*

Société NS Testut SAS, 957 rue de l'Horlogerie,
B.P. 11, 62401 Béthune, France

- ▶ **Issuing Authority / Autorité de délivrance**
Laboratoire National d'Essais, France

R76/1992-FR-98.02 Rev. 3

Balance électronique TESTUT modèle B200P (Classe III)

Société NS Testut SAS, 957 rue de l'Horlogerie,
B.P. 11, 62401 Béthune, France

R76/1992-FR-99.03 Rev. 1

Balance modèles B350M et B350T (Classe III)

Société NS Testut SAS, 957 rue de l'Horlogerie,
B.P. 11, 62401 Béthune, France

- ▶ **Issuing Authority / Autorité de délivrance**

**National Weights and Measures Laboratory (NWML),
United Kingdom**

R76/1992-GB-00.01

GX-xx and GF-xx (Class II)

A&D Instruments Ltd., Abingdon Science Park,
Abingdon, Oxford OX14 3YS, United Kingdom

R76/1992-GB-00.02

JN75 (Class III)

Pitney Bowes Ltd, The Pinnacles, Harlow,
Essex CM19 5BD, United Kingdom

- ▶ **Issuing Authority / Autorité de délivrance**

**Netherlands Measurement Institute (NMI) Certin B.V.,
The Netherlands**

R76/1992-NL-98.06 Rev. 2

DC-688.. and DCM-688 (Class III)

Teraoka Seiko Co., Ltd., 13-12 Kugahara, 5-Chome,
Ohta-ku, Tokyo 146-8580, Japan

R76/1992-NL-00.02

DC-180 (Class III)

Teraoka Seiko Co., Ltd., 13-12 Kugahara, 5-Chome,
Ohta-ku, Tokyo 146-8580, Japan

R76/1992-NL-00.03

BWB-800MA (Class III)

Tanita Corporation (Brand names: Tanita, Rhewa),
14-2, 1-Chome, Maeno-cho, Itabashi-ku,
Tokyo 174, Japan

R76/1992-NL-00.04

HS-2 (Class III)

CAS Corporation, CAS Factory # 19 Kanap-ri, Kwangjeok-myon,
Yangju-kun, Kyungki-do, Rep. of Korea

R76/1992-NL-00.05*AM-series (Class III)*

Universal Weight Enterprise Co. Ltd., 2 - 5 Fl.,
No. 39 Pao Shing Road, Hsin Tien City,
Taipei Hsien 231, Taiwan

R76/1992-NL-00.06*AG and CG (Classes I and II)*

Mettler-Toledo A.G., Im Langacher, 8606 Greifensee, Switzerland

R76/1992-NL-00.08*SM-80 (Class III)*

Teraoka Seiko Co., Ltd., 13-12 Kugahara, 5-Chome,
Ohta-ku, Tokyo 146-8580, Japan

R76/1992-NL-00.09*SM-90 (Class III)*

Teraoka Seiko Co., Ltd., 13-12 Kugahara, 5-Chome,
Ohta-ku, Tokyo 146-8580, Japan

R76/1992-NL-00.10*DS-160 (Classes III and IIII)*

Teraoka Seiko Co., Ltd., 13-12 Kugahara, 5-Chome,
Ohta-ku, Tokyo 146-8580, Japan

► Issuing Authority / *Autorité de délivrance*

Gosstandart of Russian Federation,
Russian Federation

R76/1992-RU-99.01*BT (Class III)*

Joint Stock Company Massa-K, Moskovsky pr. 19, 198005 St.
Petersburg, Russian Federation

R76/1992-RU-99.02*BTM (Class III)*

Joint Stock Company Massa-K, Moskovsky pr. 19, 198005 St.
Petersburg, Russian Federation

R76/1992-RU-99.03*BM-150 (Class III)*

Joint Stock Company Massa-K, Moskovsky pr. 19, 198005 St.
Petersburg, Russian Federation

R76/1992-RU-99.04*IIB (Class III)*

Joint Stock Company Massa-K, Moskovsky pr. 19, 198005 St.
Petersburg, Russian Federation

R76/1992-RU-99.05*CII (Class III)*

Joint Stock Company Massa-K, Moskovsky pr. 19, 198005 St.
Petersburg, Russian Federation

R76/1992-RU-99.06*BE (Class III)*

Joint Stock Company Massa-K, Moskovsky pr. 19, 198005 St.
Petersburg, Russian Federation

R76/1992-RU-99.07*BMO-1-15M (Class III)*

Joint Stock Company Massa-K, Moskovsky pr. 19, 198005 St.
Petersburg, Russian Federation

R76/1992-RU-99.08*BII (Class III)*

Joint Stock Company Massa-K, Moskovsky pr. 19, 198005 St.
Petersburg, Russian Federation

INSTRUMENT CATEGORY
CATÉGORIE D'INSTRUMENT

**Discontinuous totalizing automatic weighing
instruments (Totalizing hopper weighers)**
*Instruments de pesage totalisateurs discontinus
à fonctionnement automatique (Peseuses
totalisatrices à trémie)*

R 107 (1997)

► Issuing Authority / *Autorité de délivrance*

Danish Agency for Development of Trade
and Industry, Division of Metrology, Denmark

R107/1997-DK-00.01*LEHS 2000 (Class 0.2)*

Leon Engineering S.A., 41, Arcadia Street,
P.O. Box 14118, 115 10 Athens, Greece

INSTRUMENT CATEGORY
CATÉGORIE D'INSTRUMENT

Fuel dispensers for motor vehicles

Distributeurs de carburant pour véhicules à moteur

R 117 (1995) [+ R 118 (1995)]

► Issuing Authority / *Autorité de délivrance*

Netherlands Measurement Institute (NMI) Certin B.V.,
The Netherlands

R117/1995-NL-97.01 Rev. 1

Model Eurotron series, respectively for the two successive manufacturers: HDM, UNIVERSAL, SPECTRA, H and PRIMA series (Class 0.5)

Tokheim, Koppens Automatic Fabrieken B.V., Industrieweg 5,
5531 AD Bladel, The Netherlands

R117/1995-NL-97.02 Rev. 1

Model Eurotron series, respectively HDM, UNIVERSAL, SPECTRA, H and PRIMA series (Class 0.5)

Tokheim, Koppens Automatic Fabrieken B.V., Industrieweg 5,
5531 AD Bladel, The Netherlands

R117/1995-NL-97.03 Rev. 1

Model Eurotron series, respectively HDM, UNIVERSAL, SPECTRA, H and PRIMA series (Class 0.5)

Tokheim, Koppens Automatic Fabrieken B.V., Industrieweg 5,
5531 AD Bladel, The Netherlands

R117/1995-NL-00.01

Model Eurotron series, respectively for the two successive manufacturers: HDM, UNIVERSAL, SPECTRA, H and PRIMA series (Class 0.5)

Tokheim, Koppens Automatic Fabrieken B.V., Industrieweg 5,
5531 AD Bladel, The Netherlands

Committee Drafts received by the BIML
2000.02.01–2000.04.30

Title	Language	CD n°	TC/SC	Country
Compressed gaseous fuel measuring systems for vehicles	E	1 CD	TC 8/SC 7	Belgium/France
Revision of R 87 <i>Net content in packages</i>	E	1 CD	TC 6	USA
Revision of R 111 <i>Weights of classes E₁, E₂, F₁, F₂, M₁, M₂, M₃ (including weights for testing high capacity weighing machines)</i>	E	2 CD	TC 9/SC 3	USA



Réunion de OIML TC 8/SC 7

Mesurage des gaz

Paris, 20-24 mars 2000

Participation: Allemagne, Australie, Belgique, Brésil, Canada, Chine, Danemark, États-Unis, France, Japon, Pays-Bas, Royaume-Uni, Slovaquie

Organisations en liaison: ENGVA et IANGV

Co-Secrétariat: Belgique et France

Deux réunions se sont tenues du 20 au 24 mars 2000 dans les locaux de *Gaz de France*, Levallois-Perret, Région Parisienne. Ph. Degavre (Belgique) a présidé la réunion du 20 au 23 et R. Eggermont (Belgique) en a assuré le secrétariat durant cette même période, ainsi que la présidence le 24.

Première réunion

Les deux premiers jours étaient consacrés à l'examen du premier projet de comité (1 CD) intitulé *Ensembles de mesurage pour le gaz naturel comprimé (GNC) pour les véhicules à moteur*, qui avait été préparé par le secrétariat suite aux décisions de la réunion du sous-comité OIML TC 8/SC 7 du 8 au 11 février 1999 à Bruxelles. Le secrétariat avait reçu de nombreux commentaires écrits de la part de l'Allemagne, de l'Australie, des États-Unis et du Japon. Le but de cette réunion était donc d'examiner ceux-ci, du moins les points essentiels suivants:

- Indications en masse/volume/énergie (ces deux dernières indications à titre informatif);
- Champ opérationnel des systèmes;
- Quantité mesurée minimale (MMQ);
- Étendue entre le Q_{\min} et le Q_{\max} ;
- Exigences métrologiques pour le système et pour le compteur (en particulier les erreurs maximales tolérées et leurs conditions d'application);
- Approbation de modèle, vérification primitive, vérification sur site;
- Essais, en particulier l'essai d'endurance. Un groupe de travail (WG 1 - secrétariat France/Belgique) a été constitué

afin de produire un projet de procédures d'essai au plus tard pour septembre 2000.

Un consensus a été obtenu sur chaque point essentiel, à l'exception des essais pour lesquels le groupe de travail WG 1 fera des propositions; le secrétariat préparera un deuxième projet de comité (2 CD) qu'il soumettra au vote formel du sous-comité TC 8/SC 7 avant la fin 2000. Si ces votes sont positifs, le projet sera soumis au CIML pour approbation début 2001, et s'il y a lieu, en procédure parallèle CIML/ (TC 8/SC 7) en vue d'accélérer l'adoption de ce projet.

Deuxième réunion

La deuxième réunion concernait les *Ensembles de mesurage pour gaz combustible*; le secrétariat avait distribué le premier projet de comité (1 CD) en décembre 1999. Les pays les plus intéressés par ce sujet (Allemagne, Australie, États-Unis, Royaume-Uni) avaient fait de très nombreux commentaires; il y avait lieu de se borner à examiner l'essentiel et de confier la tâche restante à un groupe de travail (WG 2). Les délégués ont approuvé cette ligne de conduite. Il a été décidé de confier le développement des points relatifs à l'énergie et au pouvoir calorifique au WG 2, pour lequel des experts ont été désignés. Ces travaux ont été lancés lors des débats du vendredi 24, sur base d'une proposition française dont les lignes directrices ont été approuvées; ils se poursuivront au cours d'une réunion du WG 2, prévue pour les 2 et 3 mai 2000 à Bruxelles.

Les autres points essentiels, pour lesquels TC 8/SC 7 a pu dégager un consensus au cours de la réunion des 22 et 23 mars 2000, sont les suivants:

- Clarification de certaines définitions (système, module de mesurage, facteur de correction, communications sécurisées, Q_{\max} , dispositif de détermination du pouvoir calorifique, erreur moyenne pondérée, etc.);
- Composants d'un système de mesurage;
- Principes relatifs aux erreurs maximales tolérées;
- Exigences techniques pour l'installation des compteurs;
- Conversion en volume aux conditions de base ou en masse; et
- Conversion en énergie (principes).

Le secrétariat préparera un deuxième projet de comité (2 CD) qu'il soumettra au TC 8/SC 7 avant septembre 2000. La prochaine réunion est planifiée du 29 janvier au 1^{er} février 2001 à Bruxelles. ■

Meeting of OIML TC 8/SC 7

Gas metering

Paris, 20–24 March 2000

Participation: Australia, Belgium, Brazil, Canada, China, Denmark, France, Germany, Japan, Netherlands, Slovakia, United Kingdom, United States

Liaison Organizations: ENGVA and IANGV

Co-Secretariat: Belgium and France

Two meetings were held from 20 to 24 March 2000 at *Gaz de France*, Levallois-Perret, near Paris. Ph. Degavre (Belgium) chaired the meeting from 20 to 23 with R. Eggermont (Belgium) as Secretary; Mr. Eggermont also chaired the meeting on the 24th.

First Meeting

The first two days were devoted to examining the first Committee Draft (1 CD) entitled *Compressed gaseous fuel measuring systems for vehicles*, which had been drawn up by the secretariat in line with the decisions taken by OIML Subcommittee TC 8/SC 7 at its meeting held from 8 to 11 February 1999 in Brussels. The secretariat had received a number of written comments from Australia, Germany, Japan and the USA; the aim of this meeting was therefore to examine these, or at least the following main points:

- Indications of mass/volume/energy (the last two being for information purposes);
- Operational field of the systems;
- Minimum measured quantity (MMQ);
- Span between Q_{\min} and Q_{\max} ;
- Metrological requirements for the system and for the meter (especially maximum permissible errors and their conditions of application);
- Type approval, initial verification, on-site verification;
- Tests, especially the endurance test. A working group (WG 1 - secretariat France/Belgium) was formed to draw up draft test procedures by September 2000 at the latest.

Agreement was reached on each main point with the exception of the question of tests, for which WG 1 will come up with proposals. The secretariat will draw up a second Committee Draft (2 CD) and will submit it for formal voting by TC 8/SC 7 before the end of 2000. If the outcome is positive, the draft will be submitted for approval by the CIML at the beginning of 2001 and (if applicable) a simultaneous CIML - TC 8/SC 7 approval procedure will be operated in order to speed up acceptance of the draft.

Second Meeting

The second meeting concerned *Measuring systems for gaseous fuel*, for which the secretariat had sent out a 1 CD in December 1999. Those countries that are most interested in this field (Australia, Germany, UK, USA) had submitted a large number of comments; there was a need to concentrate on examining the main aspects and to allocate the remaining points to a working group (WG 2). Delegates approved this way of proceeding. It was decided to entrust WG 2 with the development of points relating to energy and calorific power, for which experts were designated. This work was started off during the discussions held on Friday 24 on the basis of a French proposal, the main theme of which was approved, and will be furthered during a meeting of WG 2 scheduled for 2–3 May 2000 in Brussels.

The other main points for which TC 8/SC 7 obtained agreement during the meetings on 22 and 23 March were:

- Clarification of certain definitions (system, measuring module, correction factor, secure communications, Q_{\max} , calorific power determination device, average weighted average, etc.);
- Components of a measuring system;
- Principles relating to maximum permissible errors;
- Technical requirements for the installation of meters;
- Conversion into volume at base conditions or into mass; and
- Conversion into energy (principles).

The secretariat will draw up a second Committee Draft (2 CD) which it will submit to TC 8/SC 7 before September 2000. The next meeting is scheduled for 29 January to 1 February 2001 in Brussels. ■

SADCMEEL Meeting

Gaborone, Botswana

10 April 2000

The Southern African Development Community's bodies specializing in standardization, metrology, accreditation and quality met in Botswana in the week 10–14 April 2000. The first day was devoted to legal metrology with a SADCMEEL meeting chaired by Mr. Brian Beard (CIML Member for South Africa) assisted by Mr. Karani (Zimbabwe) as SADCMEEL Co-ordinator and Secretariat.

The meeting was attended by representatives from Angola, Botswana, Lesotho, Malawi, Mauritius, Mozambique, Namibia, Seychelles, South Africa, Swaziland, Tanzania, Zambia and Zimbabwe (out of which 3 are OIML Member States and 5 OIML Corresponding Members), from the COMESA (Common Market for Eastern and Southern Africa), the SADC Secretariat and the BIML.

The following main topics were discussed:

- the establishment of a SADC Resource Centre for Metrology Education, jointly operated by SADCMEEL, SADC MET (metrology) and SADCA (accreditation);
- the development of application papers to certain OIML Recommendations (e.g. application of R 76 to simple non-self-indicating weighing instruments);

- the organization of technical training seminars (as a continuation of the seminar held in Harare in 1998 on non-automatic weighing instruments, with Dr. Volkmann (Germany) as expert and documentation provided by the BIML);
- representation of SADCMEEL at the next OIML Conference;
- next SADCMEEL meeting with a seminar on the verification of fuel dispensers;
- cooperation with other regional bodies and use of their expertise at Southern African level (e.g. use of "train-the-trainer" videos developed by Australia for the APLMF); and
- development of a SADCMEEL web site.

At the end of the meeting the participants proceeded with the election of a new bureau; Mr. Tukai from Tanzania (and CIML Member) was elected Chairman and Mr. Beard took over responsibility for the SADCMEEL secretariat.

The BIML Director made a presentation of certain OIML activities, focusing on:

- the importance of regional cooperation;
- OIML Development Council activities;
- cooperation between the OIML and other international bodies (WTO, UNIDO) in connection with assistance to development; and
- information on OIML membership and the procedure to become an OIML Corresponding Member.

This was supplemented by a distribution of the OIML informative brochure to participating countries and by a presentation of the OIML web site. ■

COOMET Working Group on Legal Metrology

Braunschweig, Germany 5-7 April 2000

The meeting of the recently established WG was attended by 19 participants (of whom 5 are CIML Members) from 10 COOMET member countries, plus Mr. Klenovský (Czech Rep.) and Mr. Szilvássy (BIML) as observers.

Prof. Dr. M. Kochsiek opened the meeting and emphasized that the PTB intends to continue active cooperation with COOMET in the future.

Mr. H. Apel (PTB), WG Convener, emphasized that the items on the agenda would be introduced by short presentations, but that the main emphasis should be placed on discussions and on the exchange of information and expertise. The most important outcomes of the meeting would be recommendations that would form the basis of the Working Group's future working plan.

Main topics of the agenda

- Legal metrology in COOMET member countries (R. Hahneward);
- Needs for requirements for measuring devices due to software implications (H. Apel);
- PTB database for measuring instrument type approval certificates (MITAC) (Dr. Meier);
- WELMEC Software Guide 7.1 (Dr. Schwartz);
- Possibilities for testing software in measuring instruments - prevention of manipulation (Dr. Grottker);
- Recent developments in the OIML (A. Szilvássy);
- Introduction to the revision of OIML D 9 *Principles of metrological supervision* (P. Klenovský);
- Confidence-creating measures for mutual acceptance of test results during type approval of measuring instruments (H. Apel);
- Quality of measuring instruments - calibration versus verification (Dr. Sommer).

Main recommendations of the Working Group on Legal Metrology

- To modify the COOMET MoU in order to lay down the organizational structure, tasks and competence of its bodies including issues of financing, decision making, etc.

- To restrict the Working Group's activities to questions of legal metrology (subjects related to accreditation or quality systems should be dealt with by separate working groups).
- Intercomparisons to be provided in the field of legal metrology (e.g. type approval procedures for weighing instruments, including uncertainty analyses).
- To continue mutual exchange of national documents in the field of legal metrology including technical standards and requirements for specific kinds of measuring instruments.
- The COOMET directory is to be updated and supplemented by a specific part dealing with legal metrology.
- To establish a COOMET web site, if possible bilingual.
- To intensify cooperation with other regional legal metrology organizations, and the exchange of information, including working results (for example, training courses).
- Member countries should submit their comments on the draft revision of OIML D 9 to the COOMET Secretariat to obtain a harmonized opinion.
- To set up a sub-working group *Test and protection of software for measuring instruments subject to legal control* and cooperate with OIML TC 5/SC 2.
- To set up a sub-working group *Database for the type approval of measuring instruments*.
- To continue the activities of the Working Group on legal metrology and to prepare a concept for its next meeting which allows for effective handling of the proposed subjects.

The results of the WG meeting were reported to the COOMET General meeting, held in Almaty (Kazakhstan) on 25-26 May 2000.

The Belarussian delegation offered to organize the next meeting of the Working Group. ■



Delegates attending the COOMET Working Group Meeting

4th International Symposium on Metrological Assurance

Metrología 2000

La Habana, Cuba 28–30 March 2000

The *Fourth International Symposium on Metrological Assurance* took place at the Palacio de Convenciones de La Habana in Havana, Cuba from 28 to 30 March 2000. These symposia have been organized approximately every three years since 1990.

The event was organized by the Cuban National Bureau of Standards (NC) and was attended by 170 participants, representing 14 countries of the Americas, the Caribbean, Europe and Asia, as well as Mrs. G.E.M Annabi (representing the OIML Development Council) and Ian Dunmill (representing the BIML).

The opening and closing ceremonies were conducted by Jose Luis Rodriguez Garcia, Vice President of the Minister's Council and Member of the State Council of the Republic of Cuba, Pedro Miret Prieto, Vice President of the Minister's Council of the Republic of Cuba, Leonel Amador, Vice Minister of Light Industry, Hector Perez Paez, President of the Chamber of the Republic of Cuba, Lionel Enriquez Rodriguez, President of NC and Martín Antúnez Ramírez, Director of Metrology in NC and CIML Member for Cuba.

There were 27 presentations on topics covering a wide range of scientific and legal metrology, such as:

- The law of metrology in Cuba
- Quality systems for the accreditation of calibration laboratories
- OIML activities and trends in legal metrology
- The role and activities of the OIML Development Council
- Metrological assurance under ISO 9000 in the biopharmaceutical industry
- Mass standards: calibration and intercomparisons
- Gauge blocks: uncertainties and intercomparisons
- Standard measuring tapes
- Volumetric measurements: automation, uncertainties and intercomparisons
- Creation of a national temperature standard
- Reference materials and spectrometry
- Calibration of atomic absorption spectrometers
- Determination of hardness by means of elasticity
- Vacuum metrology
- Magnetic measurements
- Metrological conformity of densitometers
- Ionizing radiation dosimeters
- Gamma ray sources for radiopharmacological applications
- The development of a universal source for electrical measurements
- Selection criteria for metrological test equipment
- The development of a mobile laboratory

Papers were presented by representatives of all of Cuba's provinces, these having been selected by the "Forum Ramal de Ciencia y Técnica" which took place in February 2000.

It is hoped that some of these papers can be presented in future editions of the OIML Bulletin. ■



La Habana, Cuba



BUREAU INTERNATIONAL DE MÉTROLOGIE LÉGALE

11, RUE TURGOT, 75009 PARIS, FRANCE

TEL: 33 (0)1 48 78 12 82 AND 33 (0)1 42 85 27 11

FAX: 33 (0)1 42 82 17 27

E-MAIL: biml@oiml.org

INTERNET: www.oiml.org

Assessment of OIML Activities

1999

Contents

- 1 OIML Member States and Corresponding Members
- 2 New and revised OIML Recommendations, Documents and other Publications issued
- 3 OIML Technical Committees and Subcommittees:
Meetings and degree of participation of OIML Members
- 4 Liaisons with other international and regional bodies
- 5 Implementation of OIML Recommendations by OIML Members
- 6 Categories of measuring instruments covered by the OIML Certificate System
- 7 Cumulative number of registered OIML certificates (as at the end of 1999)
- 8 Distribution of the OIML Bulletin and revenue from sales of OIML Publications
- 9 Connections to and development of the OIML Internet site
- 10 Activities in support of development

Assessment of OIML Activities

1999

1 OIML Member States and Corresponding Members

<i>Member States:</i>	57	(+1)	Croatia
<i>Corresponding Members:</i>	48	(+2)	Burkina Faso, Ghana, Paraguay, – Croatia
Total:	105	(+ 3)	

2 New and revised OIML Recommendations, Documents and other Publications issued

<i>New Recommendation issued:</i>	1	R 127
<i>Revised Recommendation issued:</i>	1	R 93
<i>Annexes to Recommendation issued:</i>	1	R 122, Annex C
<i>Recommendation withdrawn:</i>	-1	R 64 (<i>incorporated into R 65</i>)
<i>New Document issued:</i>	1	D 26

	1998	1999
Total number of Recommendations:	108	108
Total number of Documents:	25	26
Total number of other Vocabularies:	3	3
Total number of other Publications:	17	17

3 OIML Technical Committees and Subcommittees: Meetings and degree of participation of OIML Members

TC 3	1–3 June 1999	Paris	16 P-members present out of 25
TC 8 (WG 1)	12 February 1999	Bern	8 P-members of WG 1
TC 8/SC 5 (WG 2)	6–7 July 1999	Teddington	8 P-members of WG 2
TC 8/SC 5 (WG 2)	4–5 November 1999	Gaithersburg	8 P-members of WG 2
TC 8/SC 7	8–11 February 1999	Brussels	14 P-members present out of 17
TC 9/SC 3	15 October 1999	Borås	Informal meeting during the Workshop on Weights
TC 13	5 March 1999	Frankfurt	12 P-members present out of 18

4 Liaisons with other international and regional bodies

BIML representatives participated in the following meetings in 1999:

WELMEC	28–29 January	Budapest	<i>Committee Meeting</i>
	23–24 September	Warsaw	<i>Committee Meeting</i>
COLAMEL	23–24 February	Montevideo	<i>First Meeting</i>
European Commission	22 March	Brussels	<i>Meeting on the “MID”</i>
	8 June	Brussels	<i>Meeting on the “MID”</i>
UN/ECE	17–19 May	Geneva	<i>Working Party and Seminar on the implementation of international standards</i>
IMEKO	14–16 June	Osaka	<i>World Congress</i>
WTO TBT Committee	8–9 June	Geneva	<i>Symposium on conformity assessment procedures and Committee Meeting</i>
APLMF	7–9 September	Bali	<i>Committee Meeting</i>
IAF	29 September	Vienna	<i>General Assembly</i>
ILAC	19–20 October	Rio de Janeiro	<i>General Assembly</i>
ISO/DEVCO	18–20 October	Beijing	<i>Annual Meeting</i>
CEN/CENELEC	30 November	Brussels	<i>Meeting</i>

In addition, the CIML President, Immediate Past President, Vice-Presidents and certain CIML Members have represented the OIML at meetings of:

APLMF - COOMET - EUROMET - METROSUL

Concerning various technical activities of ISO, IEC, CEN, CENELEC and the European Commission, OIML experts participated in meetings and/or reports were given for the following fields:

- Water meters;
- Draft European Directive on Measuring Instruments (MID);
- Thermometers;
- Acoustic measurements; and
- Electromagnetic interference.

5 Implementation of OIML Recommendations by OIML Members

The last inquiry on the implementation of OIML Recommendations was carried out in 1996. A new inquiry is currently being conducted and the results will be presented at the Eleventh International Conference of Legal Metrology in October 2000.

6 Categories of measuring instruments covered by the OIML Certificate System

Twenty-eight categories of measuring instruments are covered by the following OIML Recommendations:

R 31	R 60	R 88	R 102	R 107	R 114	R 122
R 50	R 61	R 93	R 104	R 110	R 115	R 123
R 51	R 76	R 97	R 105	R 112	R 116	R 126
R 58	R 85	R 98	R 106	R 113	R 117/118	R 127

Total number of categories	1996	1997	1998	1999
	16	21	25	28
	+ 31 %	+ 19 %	+ 12 %	

7 Cumulative number of registered OIML certificates (as at the end of 1999)

<i>Category:</i>	Nonautomatic weighing instruments (R 76)	258
	Load cells (R 60)	207
	Automatic catchweighing instruments (R 51)	50
	Automatic gravimetric filling instruments (R 61)	26
	Fuel dispensers for motor vehicles (R's 117/118)	26
	Gas meters (R 31)	5
	Automatic weighing instruments (R 107)	5
	Continuous totalizing automatic weighing instruments (R 50)	4
	Clinical electrical thermometers (R 115)	1
	Cumulative total, as at the end of 1999	582

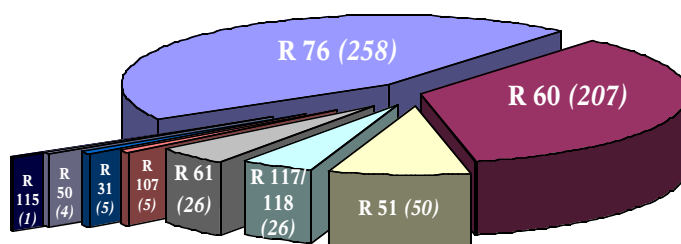

OIML certificates by category

Cumulative number of registered certificates			
1996	1997	1998	1999
226	318	452	582
+ 40 %	+ 42 %	+ 29 %	

8 Distribution of the OIML Bulletin and revenue from the sale of OIML Publications

	1996	1997	1998	1999
Total number of Bulletins distributed quarterly	1045	1039	1039	1044
	- 0.6 %	=	+ 0.5 %	
... of which Bulletin subscribers	180	172	170	163
	- 4.4 %	- 1.1 %	- 4.1 %	
Sales of Publications (FRF)	173 943	195 668	160 930	187 272
	+ 12 %	- 18 %	+ 16.4 %	

9 Connections to and development of the OIML Internet site (www.oiml.org)

1998: average 400–500 connections per month

1999: average 1 000 connections per month

Current figure: average **1 500 connections per month** (as at May 2000)

The site is constantly being developed and expanded, and has recently been totally overhauled to render it more “user-friendly”.

Additional pages have been added, the news page is usually updated weekly, Members may download many OIML Recommendations directly (including all those applicable within the OIML Certificate System) and an increasing number of other documents (Minutes, Convention, Presentations, etc.) are freely accessible for download from a brand new “Download Page”.

Communication by e-mail is now regular, thus enabling the BIML to provide quick answers to queries, send out documents and submit Bulletin article proofs for approval with no wasted time or resources.

10 Activities in support of development

Main activities:

- Preparation, circulation and analysis of two inquiries relating to the re-constitution of the Development Council and to the needs of developing countries;
- OIML Development Council Meeting (5 October 1999, Tunis) with 72 participants;
- Re-composition of the Development Council working groups, including the establishment of terms of reference and work programs for each of them;
- Contacts with international organizations (such as ISO DEVCO, UNIDO, UN/ECE, IMEKO, WTO TBT Committee, etc.), regional metrology and legal metrology organizations and with the national legal metrology institutes of a number of developing countries;
- Participation in a joint UNIDO - PTB - OIML project involving least-developed countries in Africa;
- Elaboration of a Development Council section for the OIML web site;
- Increased participation by developing countries in the work of OIML technical committees and subcommittees.

BIML, May 2000

METROLOGIA-2000

São Paulo, SP, Brazil 4-7 December 2000

An international event organized by the Brazilian Society of Metrology

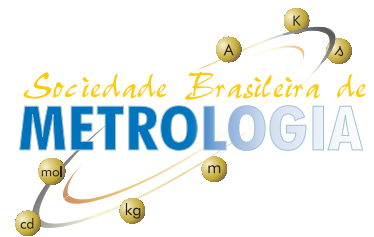

To further its mission of promoting the development of Brazilian Metrology, encouraging the adoption of modern practices and international tendencies, bringing people and institutions together and instigating the interchange of national and international specialists and experiences, the **Brazilian Society of Metrology** (SBM) has great satisfaction in announcing **METROLOGIA-2000**, an international version of the **II Brazilian Congress of Metrology**, to be held in the city of

São Paulo (Brazil) from 4 to 7 December 2000.

METROLOGIA-2000 is being organized in the context of important celebrations related to the 500th anniversary of the discovery of Brazil. It also marks 100 years of the Quanta Max Plank Theory, announced in 1900, allowing - one century later - the genesis of today's technology, based on the fundamental constants of physics. This is the theme under which **METROLOGIA-2000** will take place, "promoting metrology in the light of great discoveries".

METROLOGIA-2000 is a strategic event, and will be attended by professionals from the Brazilian business community, together with academics, renowned specialists, researchers and metrologists from other countries linked to important international metrological organizations.

Despite the specialist nature of the Associated Events (see below), the Congress is an international event that is open to all those interested in metrology.

1. Structure

- (i) **General Congress;**
- (ii) **Exhibitors** (Laboratories, Manufacturers and Distributors of Measuring Instruments);
- (iii) **Technical Sessions** with the presentation of original work in metrology focusing techniques, methods and procedures for calibration and testing related to measurements and the expression of associated uncertainties;
- (iv) **Seminar and Discussion Session** given by internationally respected specialists;
- (v) **Education and Training Module**, made up of specialist metrology courses for selected small groups, reflecting previously identified demands; and
- (vi) **Associated Events** (see opposite).

2. Themes

- ▶ Scientific and industrial metrology;
- ▶ Legal metrology;
- ▶ Instrumentation, automation and infrastructure for metrology;
- ▶ Metrology, laboratory quality and confidence;
- ▶ Accreditation of laboratories;
- ▶ International recognition of the accreditation scheme;
- ▶ Social and economic relevance of metrology;
- ▶ Advances and applications in different specialties of metrology, including chemical, electrical, optical, mechanical, thermal, acoustic and vibrations, ionizing radiation, time and frequency, rheological characterization of fluids; and
- ▶ Research, development and education in metrology.

3. Associated Events

- ▶ **METROCHEM** (II Inter-American Congress on Metrology in Chemistry)
Coordinator: Vera Ponçano (IPT), poncano@ipt.com.br
- ▶ **SEMETRO** (IV International Seminar on Electrical Metrology)
Coordinator: Luiz Carlos Santos (DIMCI/INMETRO), lcgomes@inmetro.gov.br
- ▶ **SEMEL** (International Seminar on Legal Metrology)
Coordinators: Júlio César Felix (IPEM/PR, Paraná Metrology), jfelix@tepar.br and Roberto L. Guimarães (INMETRO), rlguimaraes@inmetro.gov.br
- ▶ **METRO-TELECOM** (II Seminar on Metrology in Telecommunication)
Coordinator: Celso Pinto Saraiva (CPqD), celso@cpqd.com.br
- ▶ **METROPT** (Advances in the Application of Optical Metrology)
Coordinator: Carlos Alberto Massone (INMETRO), diopt@inmetro.gov.br
- ▶ **ENLAB** (II National Encounter of Accredited Laboratories)
Coordinators: Galdino Guttman Bicho (INMETRO), ggbicho@inmetro.gov.br and Helio Lionel (CENPES/Petrobras), lionel@openlink.com.br

Note: ENLAB-2000 is open to all laboratories, accredited or not, interested in advances in metrology, notably in the economic benefits associated with accreditation and the implications due to the transformation of the ISO/IEC Guide 25 into the new Standard ISO/IEC 17025.

4. Call for technical papers / scientific contributions

With the aim of giving an outlet for technical-scientific production in metrology and to create a specialized forum to debate and divulge this important intellectual production, the **Brazilian Society of Metrology** invites specialists and professionals involved in research and the rendering or utilization of metrological services, to submit original articles with proven contribution for presentation in the Technical Sessions. The paper should be in the form of a Summary, in A4 format, maximum of one page, describing the contribution, the authors, positions and complete institutional and e-mail addresses for contact.

After analysis of the Summaries, the authors will receive editorial instructions and invitations to submit the full paper, permitting the Editorial Board to approve its inclusion in the *Proceedings of METROLOGIA-2000*, as well as its eventual recommendation for submission for publication in the *Revista Brasileira de Metrologia* (RBM). This is the SBM's commitment in demonstrating national competence in metrology and promoting an intense interaction and effective networking around the diverse themes related to science, technology and the art of measurement. The process of the inclusion of papers in the Technical Sessions will be:

- Submission deadline for Summaries: 17 July 2000
- Notification of Summary acceptance: 31 July 2000
- Deadline for full Paper submission: 18 Oct. 2000
- Notification of Paper acceptance: 1 Nov. 2000

5. Organizational Commission of METROLOGIA-2000

- | | |
|--|---|
| ▶ Armando Mariante (INMETRO President) | ▶ José Joaquim Vinge (INMETRO) |
| ▶ José Manuel de Aguiar Martins (SENAI-DN President) | ▶ Júlio César Felix (IPEM/PR) |
| ▶ Maurício Nogueira Frota (President, SBM and METROLOGIA-2000) | ▶ Luiz Carlos Santos (INMETRO) |
| ▶ Alfredo G. R. Oliveira (Hidroquímica) | ▶ Mário Bonatti Maurício (Panambra) |
| ▶ Carlos Alberto Massone (INMETRO) | ▶ Mauro Miaguti (FIESP) |
| ▶ Celso Pinto Saraiva (CPQD) | ▶ Ozires Silva (SBM/Council, VARIG President) |
| ▶ Galdino Guttman Bicho (INMETRO) | ▶ Pedro Buzatto Costa (Abimaq) |
| ▶ Hélio Lionel (CENPES/Petrobras) | ▶ Reinaldo Ferraz Dias de Souza (MCT) |
| ▶ Jorge Milton Elian Saffar (CETEC) | ▶ Roberto L. Lima Guimarães (INMETRO) |
| | ▶ Vera Ponçano (IPT) |
| | ▶ Wilson Radi El Maftoum (LACTEC) |

In addition to the organizational and operational tasks, this Committee will benefit from the support and experience of members of the SBM that form the technical-scientific community to evaluate the papers submitted to the Technical Sessions.

6. International Scientific Advisory Committee

With the purpose of assuring the quality and relevance of **METROLOGIA-2000**, i.e. to reflect current themes and advances in metrology and its impact on health, the environment, the quality of life and the development of competitiveness, the Organizational Commission will benefit from the advice and orientation of an **International Scientific Advisory Committee** of a high level which brings together specialists from Brazil and from the principal international Metrology Organizations, formed by:

- | | | |
|--|--|--|
| ▶ Birch, John (Asia-Pacific Legal Metrology Forum, Australia) | ▶ Gilmour, John (ILAC, NATA, Australia) | ▶ Plantenga, T. Menno (NMI, The Netherlands) |
| ▶ Birkeland, Knut (OIML, Spain) | ▶ Kirschstein, Sven Christian (CODELECTRA, Venezuela) | ▶ Popa, Marcel (Technical University Cluj-Napoca, Romania) |
| ▶ Bode, Peter (Technical University of Delft, The Netherlands) | ▶ Kochsiek, Manfred (OIML, PTB, Germany) | ▶ Schneider, C.A. (Certi, Brazil) |
| ▶ Bonnier, Georges (BNM, France) | ▶ Laiz, Hector (INTI, Argentina) | ▶ Seiler, Eberhard (IMEKO, PTB, Germany) |
| ▶ Carneiro, Kim (DFM, Denmark) | ▶ Lira Canguilhem, Ignacio (Asociación Chilena de Metrología, Chile) | ▶ Semerjian, Hratch G. (NIST, USA) |
| ▶ Carpenter, Stephen (NIST, USA) | ▶ Moscati, Giorgio (CIPM, Brazil) | ▶ Valdes, Joaquim (CIPM, Univ. San Martin, Argentina) |
| ▶ Chambon, Maguelonne (BNM, France, Euromet) | ▶ Nava Jaimes, Hector (CENAM, Mexico) | ▶ Wallard, Andrew (CIPM, NPL, UK) |
| ▶ Decker, Jennifer (NRC, Canada) | ▶ Pfeifer, Tilo (IMEKO, Univ. Aachen, Germany) | |
| ▶ Delgado, Cecília (Asociación Mexicana de Metrología) | | |

7. Further information

General information can be obtained from the Executive Office of the **Brazilian Society of Metrology**



Guilherme HUGUET
Executive Secretary, SBM
Tel: (55) 21 544-5751, ext. 211
Fax: (55) 21 544-5527
E-mail: sbm@redetec.org.br

Maurício Nogueira FROTA
President, SBM and **METROLOGIA-2000**
E-mail: mfrota@mec.puc-rio.br

or directly from the respective Coordinators of the **Associated Events** for technical information. Current information is permanently available at the **Brazilian Society of Metrology** web site: www.sbm metrologia.org.br

**The OIML
is pleased to welcome
the new **CIML Member**
for Japan:**

Mr. H. Imai



October 2000

9-13	11 th International Conference of Legal Metrology 35 th CIML Meeting Development Council Meeting Round Table	LONDON
------	---	--------



November 2000

To be confirmed	TC 8/SC 5 Water meters	TBA
-----------------	------------------------	-----

January/February 2001

To be confirmed	TC 8/SC 7 Gas metering	BRUSSELS
-----------------	------------------------	----------

i n f o

The *International Laboratory Accreditation Cooperation* (ILAC) is the world's principal international forum for the development of laboratory accreditation practices and procedures. ILAC promotes laboratory accreditation as a trade facilitation tool, assists developing accreditation systems, and recognizes competent test facilities around the globe.

This year marks the 22nd year of ILAC's existence, and both the ILAC 2000 Planning Committee and the Conference Administrative Sponsor, Excel Partnership, have committed considerable planning and effort into making ILAC 2000 as rewarding as possible for all participants.

A General Assembly of ILAC members will be held on Monday morning, Thursday afternoon and Friday. All attendees are invited to the opening session on Monday morning. The Thursday and Friday sessions are for ILAC members and invited guests. These sessions will cover Committee Reports and general ILAC business, and attendees may contact an ILAC member to coordinate possible attendance.

ILAC 2000 Technical Conference Agenda

<p>Technical Session 1 – Monday 1:30-5:00</p> <p>Technical Session 2 – Tuesday 8:30-12:00</p> <p>Technical Session 3 – Tuesday 1:30-5:00</p> <p>Technical Session 4 – Wednesday 8:30-12:00</p> <p>Special Tutorial: Wednesday 1:30-5:00</p> <p>Laboratory Tours: Thursday 8:00-12:00</p>	<p>Application of ISO 17025: Determining the Competence of Testing and Calibration Laboratories</p> <p>Stakeholder Reliance on Accredited Laboratories</p> <p>Proficiency Testing and Interlaboratory Comparisons</p> <p>Uncertainty and Traceability: How Good are the Data?</p> <p>Uncertainty Analysis</p>
--	---

Contacts:

John Locke - Chair, ILAC 2000 Planning Committee
Belinda Collins - Chair, ILAC 2000

Tel: 1-703-680-1436 (USA)
Web site: www.ilac2000.com